

2023-2024



STUDENT HANDBOOK

Orangeburg Preparatory Schools, Inc.

Upper Campus
2651 North Road NW
Orangeburg, S.C. 29118
Phone: (803) 534-7970
Fax: (803) 535-2190

Lower Campus
168 Prep Street
Orangeburg, S.C. 29118
Phone: (803) 536-3000

Student Handbook
Lower, Middle, and High School
belongs to

Name

Address

City/Town

Phone

Zip

Homeroom

School ID # 411553



Staff, Board, & Organizations

ADMINISTRATION

Libby Ray, *Head of Schools*
 Connie Porth, *Lower Campus Administrator*
 Mrs. June Kemp, *Child Development Center Director*
 Mrs. Taylor Riley, *Guidance Counselor*
 Coach Jan Stoudenmire, *Athletic Director*

SUPPORT STAFF

Paula Edwards, *Office Assistant*
 Tommy Fogle, *Maintenance Supervisor*
 Tracey Kearse, *Business Office Manager*
 Beth Kuck, *School Nurse*
 Kristen Pascoe, *Lower Campus Administrative Assistant*
 Sandy Reed, *Executive Assistant to the Head of School*
 Sherry Rutland, *Upper Campus Student Services
 Administrative Assistant*

BOARD MEMBERS

Michael Delaney, *Chairman of the Board*
 Jack Bryant, *Vice Chairman of the Board*
 Martha Burleson, *Secretary of the Board*
 Rebekkah Brailsford, *Treasurer of the Board / ATP Rep*
 Parker Dempsey, *Director*
 Dr. Thomas Gue, *Director*
 Jim Holstein, *Director*
 Tate Jameson, *Director*
 Leroy Ravenell, *Director*

BOOSTER CLUB OFFICERS

President: Allen Fairey
 Vice President: Marji Albergotti
 Secretary: Shelly Sutcliffe
 Treasurer: Robbie Myers

ATP OFFICERS

President: Ashleigh Phillips
 Vice-President: Katherine Smith
 Treasurer: Lynn Whetsell
 Secretary: Brittany Price
 ATP Representative: Rebekkah Brailsford

ALMA MATER

Hail to thee, oh mighty Indians
 Let us sing our praise.
 We pledge our faith and love forever,
 During our school days.

Hail to Orangeburg Preparatory
 Forever stand we pray.
 With loyalty and pride forever,
 Hail the Red and Gray.

SCHOOL MASCOT: INDIANS

SCHOOL COLORS:
 Red, White, & Gray

OPS PRIDE PLEDGE

Promise to be kind
 Responsibility is key
 I will cooperate
 Do my best
 Everybody deserves respect



Upper Campus
 2651 North Road NW
 Orangeburg, S.C. 29118
 Phone: (803) 534-7970
 Fax: (803) 535-2190

Lower Campus
 168 Prep Street
 Orangeburg, S.C. 29118
 Phone: (803) 536-3000

WELCOME

On behalf of the faculty and administration of Orangeburg Preparatory Schools, Inc., we would like to welcome you to our school. It is our mission to provide our students the finest in educational opportunities. In order to ensure this type of educational opportunity, certain policies and procedures must be implemented. The policies and procedures contained in this handbook are the result of a combined effort on the part of the faculty, administration, and Board of Directors. This information has been carefully prepared and presented so that it will be of great value to you in understanding our school, its mission, and its daily routine. Please become familiar with the contents. The contents will aid in communication and understanding which are the basis for all relationships at Orangeburg Preparatory Schools, Inc. We wish for you a fulfilling school experience.



Mrs. Libby Ray, Head of Schools

MISSION STATEMENT

Orangeburg Preparatory Schools, Inc. seeks to provide a quality education which prepares students to meet the academic demands of college and to lead productive and fulfilling lives in a complex world.

SCHOOL BELIEFS

1. Student learning is the chief priority for our school and the primary focus of decisions impacting our school.
2. Students need to demonstrate their understanding of essential knowledge and skills and apply their learning in meaningful contexts.
3. Curriculum and instruction should provide a variety of learning experiences through diversity in course offerings, in teaching methods, and in evaluation techniques.
4. Students learn best when they are actively engaged in the learning process.
5. Challenging expectations increase individual student performance.
6. A safe and physically comfortable environment promotes student learning.
7. Students' social maturation is enhanced by stressing the importance of responsibility and respect, and emotional growth is fostered by encouraging self-discipline and self-respect.
8. Students should participate in programs which promote physical fitness, healthy living, and good sportsmanship.
9. Students' self-esteem is enhanced by positive relationships and mutual respect among teachers, administrators, staff, students, and parents.
10. Students' social, emotional, and moral education is reinforced through a variety of co-curricular and extra-curricular activities, special assemblies, and daily devotions.
11. Teachers, administrators, staff, students, and parents share the responsibility for advancing our school's mission.

HONOR CODE

Personal honor requires that every person act honorably in academic work as well as in every other phase of school life. Personal honor **MUST** involve respect for one's self and respect for others, their feelings, rights, property, and their desire to obtain the best possible education. This includes not bullying or harassing.

The student shall be on his honor to prepare and submit only his own work (i.e. copying homework, plagiarism, texting, using electronic devices, etc.) and to refrain from giving or receiving help on tests, examinations, and optional assignments (unless given prior permission by the teacher).

Accreditation

Orangeburg Preparatory Schools, Inc. is fully accredited by Cognia and the South Carolina Independent Schools Association (SCISA).

Orangeburg Preparatory Schools, Inc. was chartered on December 31, 1984, as a non-profit corporation and has qualified as a tax-exempt organization under I.R.C. Section 501(c)3. The school admits students of any race, color, and national or ethnic origin.

Admission Policy

To be considered for admission to Orangeburg Prep, all prospective students may be required to take a placement test consisting of reading comprehension, vocabulary, and math. Copies of transcripts from previous schools must be presented. The school reserves the right to determine grade placement of all students based on the documentation and to determine appropriate credits awarded. Credits transferred in will be calculated on a 5.0 scale or may be awarded as non-weighted credit. OPS further reserves the right to not accept the applicant as a student based on prior academic or disciplinary records.

Admission of Home Schooled Students: The student must provide documentation of successful completion of a comparable standardized test. Records must be supplied that indicate the subjects studied and the time devoted to each. Copies of tests and exams may also be required. All records from the Home School Association must be current. The school reserves the right to determine grade placement based on the documentation. Credit units will be calculated on a 5.0 scale or may be awarded as

unweighted credits. Students entering their senior year must pass all subjects with at least an 80 average in order to receive an Orangeburg Prep diploma.

Extra Help For Students

All teachers will be available until 3:15 p.m. to give students help. Parents are responsible for the transportation of students who stay after school. This additional help time with students takes priority over all other meetings and responsibilities of the teacher except for regularly scheduled faculty meetings on Tuesdays and emergencies. **Help sessions after school take precedence over the student's extracurricular activities.** Students are not required to report to athletic practices before 3:30 P.M.

Foreign Exchange Students

A maximum of two foreign exchange students will be granted admission in a school year. These students must possess a competent command of the English language. The student should be traveling through an approved agency. Host families will be responsible for ensuring the student is taking the appropriate courses. The year spent here should be a requirement for the student to complete the equivalent high school curriculum in their native country. Foreign students will receive only a "Certificate of Attendance" upon passing all courses taken.

Gradelink

Gradelink is the parents' communication tool to monitor their child's academic progress. It is the **parent's responsibility** to access Gradelink regularly. The password can be verified by contacting the school office.

LOWER CAMPUS ACADEMICS

Grading Scale

A	90-100
B	80-89
C	70-79
D	60-69
F	59 and below

Homework Policy

Homework is defined as any preparation for class to be written, read, or reviewed outside of class. The faculty and staff of OPS recognize that homework is effective in improving student achievement by extending a student's learning beyond the classroom. Research indicates that homework is most useful when teachers carefully plan it, explain it, and give prompt response when it has been completed. We recognize that student achievement rises when teachers regularly assign homework and students conscientiously do it. It is the teacher's responsibility to see that expectations for homework are clearly spelled out. The student is responsible for the daily preparation for each class. The parent's responsibility is to recognize that students who do their homework will have a greater chance of academic success and to help students make schoolwork a top priority. Copying other students' homework is considered an honor code violation and will result in disciplinary action.

Suggested Homework Time

Kindergarten: 10-15 minutes

Grade 1 & 2: 20-30 minutes

Grade 3-5: 60 minutes or less

Remember, these times are approximate and do not include suggested nightly reading. Children work at different rates of speed.

Promotion To The Next Grade

1. 4K and 5K: Teachers must recommend promotion.
2. Grade 1: All students must pass reading. Teachers must recommend promotion.
3. Grades 2-5: If a student in grades two through five fails one core subject, one core and one academic subject, or two academic subjects, his/her promotion is contingent upon satisfactorily completing summer school or an approved tutorial program. A student who fails two core subjects or three or more academic subjects will be required to repeat the grade.

Core/academic subjects are defined as:

Core: Reading and Math

Academic: Science, Social Studies, History, Language, and Spelling

Approved tutorial program means:

- a) a certain number of hours will be required (30 hours for a core subject, 10 hours for an academic subject)
- b) tutors must be approved by administration, be certified in the subject area, or hold a degree in that subject area
- c) the number of hours of tutoring must be documented by the tutor on the appropriate form
- d) the student may be required to pass an assessment of grade level standards/skills

UPPER CAMPUS ACADEMICS

Academic Awards and Honors

1. Valedictorian and Salutatorian- to be considered, the student must have attended Orangeburg Prep in the 9th, 10th, 11th, and 12th grades.
2. Graduation Marshal- to be considered, the student must have attended Orangeburg Prep in the 10th and 11th grades. Eligibility is determined at the end of the first semester of the student's junior year on the basis of a cumulative grade point average of 4.0 and being ranked in the top 12 of their class.
3. Other awards and honors are based on grade point averages and other designated criteria.

Class Rank

Orangeburg Preparatory Schools utilizes the South Carolina Uniform Grading Policy to determine the corresponding letter grade for each numerical grade. Orangeburg Preparatory Schools utilizes the South Carolina Uniform Grading Policy for each course that awards a Carnegie Unit. The South Carolina Uniform Grading Policy includes weighted grades for Honor or Advanced Placement courses. The South Carolina Uniform Grading Policy is used to calculate the Grade Point Average (GPA) for each course that receives Carnegie Unit credits. For the purposes of calculating the class rank, the student's cumulative Grade Point Average according to the South Carolina Uniform Grading Policy is used and students are arranged from the highest Grade Point Average reported with at least two decimal places and may not be rounded up. The class rank is calculated at the end of each semester in courses grades ten through twelve. Class ranking is used for purposes such as determining Junior Marshals, Honors at Graduation, etc. The class rank includes all students that attended Orangeburg Preparatory during the school year.

Class rank will be released upon request to students after completion of the first semester of their sophomore year.

Course Changes

1. A course (including dual credit courses) may be dropped without penalty during the first ten days of a year-long course and the first five days of a semester course. After these deadlines, a grade of WF or WP will be recorded on the transcript unless the student goes to a different level of the same course.
2. A student must have written permission from his parents, guidance counselor, and the school administration before dropping a course. The teacher will be notified using a drop/add form.
3. When a student replaces a course after the drop/add period, he cannot exempt that semester's exam and is responsible for all material missed in that class.
4. If a parent deems it appropriate for his/her child to be removed from a classroom for personal or professional reasons, Orangeburg Prep reserves the right to review these matters and make recommendations. A conference with the teacher may be deemed necessary.

Course Load

A student (except seniors when given administrative approval) must take six courses each semester while enrolled at Orangeburg Preparatory Schools, Inc. This may include 1/2 credit courses (grades 8-12). If a senior is not enrolled in dual credit courses, then two OPS courses must be taken.

Early Graduation

Orangeburg Prep students or new students coming to OPS will advance to the Senior Class only by calendar promotion.

Students desiring to graduate early will graduate from the junior class and be allowed only junior privileges and honors. Students may graduate at the end of the eleventh grade by following these procedures:

1. Students contemplating early graduation must have an overall academic average of 90 by March 1st of the tenth grade.
2. Students desiring to graduate early must have 24 or more credits at the end of the junior year. These credits must be distributed in such a way as to meet the minimum requirements for graduation at OPS and include English I, II, III, and IV.
3. Orangeburg Prep will not accept summer school credit for academic work taken in advance.
4. A written request for early graduation must be made by the parents to the guidance office by March 1st of the tenth grade year.
5. A conference with the parents, administration, and guidance counselor is mandatory following the written request.

Exams (Grades 6 - 12)

Semester exams are administered to students in grades 6-12 at the end of each semester. The second semester exams do not cover first semester material except when deemed necessary. Students who have accumulated five unexcused absences in a semester course must take the semester exam. Students who have accumulated ten unexcused absences in a yearly course must take the final exam. Examination grades count 20% of the semester grade (grades 7-12). Sixth grade exams count 15% of the semester grade. Cumulative exams are under the discretion of the teacher.

***Students must take exams during the designated period according to the semester exam schedule.**

Students may exempt the first semester under the following conditions:

- A. Seniors- (1) with at least a 90 average in year-long classes and in compliance with the OPS policies, (2) with an 85 average in an honors course and in compliance with the OPS policies, or (3) with an 80 average in an AP course and in

compliance with the OPS policies, and (4) attend the minimally required sessions of senior seminar.

- B. Students (6th-11th) may not exempt the first semester exam unless the course is a semester course.
- C. Students taking a semester course may exempt the first semester exams with the average of a 90 (seniors with a 87) and in compliance with OPS policies.

Students may exempt the second semester exams under the following conditions:

- A. Seniors- (1) with at least a 87 average for the semester and in compliance with the OPS policies, (2) with an 82 average for the semester in any honors course and in compliance with the OPS policies, or (3) with an 80 average for the semester in an AP course and in compliance with OPS policies and (4) attend the minimally required sessions of senior seminar.
- B. Students (6th-11th)- (1) have a 90 or above average for the semester and are in compliance with OPS attendance policies, (2) have an 85 in an honors course and are in compliance with OPS policies, or (3) have an 80 in an AP course and are in compliance with OPS policies.

Eligibility Requirements

- A. Extracurricular: Many activities, services, publications, special interests, and athletics, are available for student participation. However, to be eligible to participate in any extracurricular activities (such as, but not limited to, May Court, homecoming, waiter/waitress, senior superlatives, etc.), a student must be passing all subjects and must not be on administrative probation. A failure is considered to be a 59 or below. All students are required to be in school a minimum of 200 minutes of the school day if they wish to participate in an extracurricular activity. Moreover, athletics, organizations, and clubs are governed by their individual guidelines and by-laws, and additional criteria may be set. The organization's guidelines may override these policies.
 - 1. Eligibility will be determined at the end of each nine weeks.
 - 2. Eligibility is to be declared on the fourth (4th) school day after the end of the marking period. A student shall become eligible or ineligible at 12:01 AM on the fourth school day after the end of the marking period.
 - 3. The yearly grade is considered composite and conclusive and therefore overrides any nine weeks grade. First semester grades do not override the second nine weeks grades unless the course is a semester or ½ credit course.
 - 4. A student who is ineligible for extracurricular activities may not practice, travel, or in any way participate in those activities during the period of ineligibility.
 - 5. A student may not hold more than one major office without administrative approval. Major officers are Student Council President and Vice President, Class President, Publication Editors, Head Varsity and JV Cheerleader, and the president of any club or organization.
 - 6. Any middle school or upper school student who commits a Class Three Infraction or a Class Four Infraction or who is on probation in a specific organization during the year may be ineligible to continue in or run for an elected office/honor. NJHS, NHS, and Student Council have specific criteria concerning eligibility and membership.
 - 7. Participation in May Day will not be allowed if a student has a Class Three or Four Infraction in the same school year.

B. Dual Credit Requirements

- 1. Seniors will be allowed to enroll in OC Tech dual credit classes provided they have a 2.5 GPA. Students in grades 10-12 must have a 3.0 GPA to enroll in Troy dual credit classes.

*Students taking college credit courses outside of Orangeburg Prep dual credit will not receive credit towards the Orangeburg Prep GPA.

Grading Scale

A quality point system is used to determine grade point averages (GPA). Grades earned in all academic courses, including designated courses taken in the eighth grade, are used to compute GPA's. Grades earned in non-academic courses are not used to compute GPA's. Orangeburg Prep is on a 5.0 scale and follows the South Carolina Uniform Grading Scale Conversion.

10 Point Grading Scale

South Carolina Uniform Grading Scale Conversions

Numerical Average	Letter Grade	College Prep Weighting	Honors Weighting	AP/IB/Dual Credit Weighting
100	A	5.000	5.500	6.000
99	A	4.900	5.400	5.900
98	A	4.800	5.300	5.800
97	A	4.700	5.200	5.700
96	A	4.600	5.100	5.600
95	A	4.500	5.000	5.500
94	A	4.400	4.900	5.400
93	A	4.300	4.800	5.300
92	A	4.200	4.700	5.200
91	A	4.100	4.600	5.100
90	A	4.000	4.500	5.000
89	B	3.900	4.400	4.900
88	B	3.800	4.300	4.800
87	B	3.700	4.200	4.700
86	B	3.600	4.100	4.600
85	B	3.500	4.000	4.500
84	B	3.400	3.900	4.400
83	B	3.300	3.800	4.300
82	B	3.200	3.700	4.200
81	B	3.100	3.600	4.100
80	B	3.000	3.500	4.000
79	C	2.900	3.400	3.900
78	C	2.800	3.300	3.800
77	C	2.700	3.200	3.700
76	C	2.600	3.100	3.600
75	C	2.500	3.000	3.500
74	C	2.400	2.900	3.400
73	C	2.300	2.800	3.300
72	C	2.200	2.700	3.200
71	C	2.100	2.600	3.100
70	C	2.000	2.500	3.000
69	D	1.900	2.400	2.900
68	D	1.800	2.300	2.800
67	D	1.700	2.200	2.700
66	D	1.600	2.100	2.600
65	D	1.500	2.000	2.500
64	D	1.400	1.900	2.400
63	D	1.300	1.800	2.300
62	D	1.200	1.700	2.200
61	D	1.100	1.600	2.100
60	D	1.000	1.500	2.000
59	F	0.900	1.400	1.900
58	F	0.800	1.300	1.800
57	F	0.700	1.200	1.700
56	F	0.600	1.100	1.600
55	F	0.500	1.000	1.500
54	F	0.400	0.900	1.400
53	F	0.300	0.800	1.300
52	F	0.200	0.700	1.200
51	F	0.100	0.600	1.100
0-50	F	0.000	0.000	0.000
WF	F	0.000	0.000	0.000
WP	-	0.000	0.000	0.000

Graduation Requirements

Students must earn a total of twenty-four units of credit. At least twenty-one must be academic and three may be non-academic. Students must meet the following minimum requirements or their equivalent:

English	4
Math	4
Lab Sciences	3
Social Studies	3
Foreign Language (3 encouraged)	2
Computer Science	1
Physical Education	1
Fine Arts	1
Additional Units	$\frac{5}{2}$ (Four units must be academic)
Total	24

Honors and AP Courses

Criteria for Honors, AP courses, and Dual Credit can be found by contacting the Department Head.

Homework Policy

Homework is defined as any preparation for class to be written, read, or reviewed outside of class. The faculty and staff of OPS recognize that homework is effective in improving student achievement by extending a student's learning beyond the classroom. Research indicates that homework is most useful when teachers carefully plan it, explain it, and give prompt response when it has been completed. We recognize that student achievement rises when teachers regularly assign homework and students conscientiously do it. It is the teacher's responsibility to see that expectations for homework are clearly spelled out. The student is responsible for the daily preparation for each class. The parent's responsibility is to recognize that students who do their homework will have a greater chance of academic success and to help students make schoolwork a top priority. Copying other students' homework is considered an honor code violation and will result in disciplinary action.

Promotion To The Next Grade

Promotion to the next grade is contingent upon completion of certain requirements in the Middle School and in the Upper School. Students failing three or more courses will not be allowed to advance to the next grade level. Courses are defined as core subjects and academic subjects.

1. **Middle School** If a student in grades six through eight fails one core course or two academic courses, his promotion is contingent upon satisfactorily completing summer school or an approved tutorial program. A student who fails two or more core courses will be required to repeat the grade or repeat the courses in summer school. If an eighth grader fails a course that receives high school credit, he must repeat the course the next year, in summer school, or through an approved tutorial program.

In Middle School, core/academic courses are defined as

Core: English (Reading and Writing), Math Academic: Science, Social Studies, Foreign Language

Approved tutorial program means

- A certain number of hours will be required (30 hours for a core course, 10 hours for an academic course);
- Tutors must be approved by the administration, be certified in the subject area, or hold a degree in that subject area.
- The number of hours of tutoring must be documented by the tutor.
- The student must pass the course's final exam with a score of 60.
- The student will be allowed to take the exam(s) or test(s) only once to qualify for promotion.
- The tutor may not view the exam(s) or test(s) to be given.
- A grade of 60 will be recorded on their permanent record.

2. **Grades 9 - 12** In High School, grade placement will adhere to the following policies:

Grade 9 - The student shall have successfully completed grade 8 and be currently enrolled in English I.

Grade 10 - The student shall have earned at least six units of credit with one of those units being English I and currently enrolled in English II.

Grade 11 - The student shall have earned at least twelve units of credit with two of these units being English I & II and currently enrolled in English III.

Grade 12 - The student shall have earned at least eighteen units of credit including English I, II, III, and IV or currently enrolled in English IV and one unit of math (unless four units have been completed), and be in position to complete all twenty-four (24) required units of credit by graduation day.

***Units are awarded at the completion of the entire course. Students must have successfully completed 24 units of credit in order to participate in the graduation exercise.**

In grades 9-12 core/academic courses are defined as

Core: English, Math, Social Studies, Non-Lab Sciences, Electives

Academic: Lab Sciences, Non-Elective Foreign Languages

If a student fails a course during the year and meets the above requirements, the student may repeat the course during the upcoming school year. The student may also have the option of summer school or approved tutorial program for core courses only. If a student has passed the exam(s), the tutorial program is not an option.

Summer School

Grades 6-12 - Students who fail a course during the school year should repeat the course in summer school or through an approved tutorial program in order to have the necessary credits for advancement. Only one course may be repeated during the summer. Students will be allowed to take courses at a regionally accredited summer school other than Orangeburg Prep Summer School only if the course is not being offered at OPS Summer School. When a course is repeated at another school, a final grade of 60 or above is required in order to receive credit for the repeated course, and a grade of 60 (passing) is recorded on the student's transcript. A student will be allowed to make up a course in summer school only once in the subject area. Subsequent failures must be repeated during the following school year. A student has until December following the second semester of their senior year to complete the requirements for a diploma.

Orangeburg Prep will only accept summer school credit for credit recovery.

Approved tutorial program means

- a) A certain number of hours will be required (30 hours for a core course). Academic courses may not be taken through tutorial. Academic courses must be taken through an accredited summer school.
- b) Tutors must be approved by the administration, be certified in the subject area, or hold a degree in that subject area.
- c) The number of hours of tutoring must be documented by the tutor.
- d) The student must pass the course's exam with a score of 60. Exams will be administered at Orangeburg Prep on designated days.
- e) The student will be allowed to take the exam(s) or test(s) only once to qualify for promotion.
- f) The tutor may not view the exam(s) or test(s) to be given.
- g) Once successfully completed, a grade of 60 will be recorded in their transcript.

Test Schedule

Major tests are to be given according to the following schedule. For major quizzes, teachers should communicate regarding the test load for that day.

Grades 9-12

<i>Monday</i>	English and Foreign Language
<i>Tuesday</i>	History, Mathematics, Computer
<i>Wednesday</i>	Science, English, Fine Arts
<i>Thursday</i>	Foreign Language and History
<i>Friday</i>	Science, Mathematics, Computer, Fine Arts

Grades 6th-8th

<i>Monday</i>	English Language, Science, Rotation, Health
<i>Tuesday</i>	Math, History
<i>Wednesday</i>	Science, Reading, Spelling
<i>Thursday</i>	History, English Language, Rotation, Health
<i>Friday</i>	Reading, Spelling, Math

*Lower campus teachers should communicate regarding the test load for a day to ensure the schedule is manageable.

GENERAL POLICIES

ADDRESS CHANGE

Parents are asked to notify the school office when addresses, phone/cell numbers, e-mails, or places of employment change.

ARRIVAL / DEPARTURE

Early morning drop-off begins at 7:15 a.m. in the Upper Campus and Lower Campus canteens. All students arriving before 7:50 a.m. must report to the gym/cafeteria. Students are released to go to their classrooms at 7:50 a.m. when teacher supervision begins. At the end of the school day, school supervision ends at 3:00 p.m. All students must be picked up before that time. Any Lower Campus students remaining on campus will be sent to the Child Development Center and charged accordingly.

A student who arrives on campus during school hours must report to their assigned classes. If this time is after 8:10 a.m., the student must sign in at the office. Upon leaving campus at anytime during the school day, a student must sign out in Student Services. Lower Campus students must be signed out by an approved adult.

Hours:

Lower Campus 8:00 a.m.-2:30 p.m.

Upper Campus 8:00 a.m.-2:40 p.m.

ATTENDANCE

Parents and students are encouraged to keep absences, dismissals, and tardies to a minimum. We ask that all appointments be scheduled after school hours if possible. Adherence to the attendance policies teaches responsibility and promotes continuity in the classroom.

Perfect Attendance is defined as having no tardies, no dismissals, and no absences of any kind (excused or unexcused) unless the absence is due to school business. A student may only be tardy or dismissed early once for Outstanding Attendance. Early dismissal is any time prior to the child's designated dismissal time.

Absences

In order to receive credit for each course, a student may have no more than ten unexcused absences in a yearly (180 day) course or no more than five unexcused absences in a semester (90 days) course. A student must be in attendance for at least 85% of the class sessions whether an absence is excused or unexcused. This means that a student may not have more than twenty-seven absences (excused and/or ten unexcused absences) in a yearly course, and fourteen absences (excused and/or five unexcused) in a semester course. Family trips are considered unexcused absences and count toward the total number of absences a student may accumulate. Parents are responsible for checking their child's attendance on Gradelink.

If a student is absent, in order for the absence to be excused, written documentation from a doctor or dentist must be presented stating the exact dates of absence. Death or bereavement will be handled by the administration.

Students will have seven days after an absence to bring or fax a medical excuse. Failure to return a medical excuse within seven days of return to school may result in the absence being considered unexcused. After seven days, absences must be excused by an administrator. It is the student/parent's responsibility to ensure that a medical excuse has been turned in to Student Services. Students are responsible for checking Gradelink for their assignments. Excessive unexcused absences will be reported by the office to the proper authorities.

A student who chooses not to go on a field trip (including the Senior Class Trip) is expected to be in school. Absences will be unexcused without medical documentation.

Lower Campus students must arrive before 11:15 a.m. or be dismissed after 11:15 a.m. to be considered present for the school day (or the equivalent of being present for 3 hours and 15 minutes.)

Anticipated Absences

If a student anticipates an absence for any reason, he/she should bring a written excuse/request to the subject teacher at least two days before the planned absence. The student is responsible for any work missed.

College Visits

Students are encouraged to visit college campuses that they may be interested in attending. A student is allowed to take two official college visits during their junior year and two official college visits during their senior year. Documentation from the college must be provided to Student Services within two days upon returning to school in order to excuse the absence. Additional visits must have prior administrative approval.

School Related Absences

Absences due to participation in school related activities are NOT recorded as absences and require no written excuses. Students are responsible for any work missed due to school related absences and must remain current with all course work including dual credit classes upon returning to school (tests, homework, projects, etc.). Students are to check Gradelink for missed work.

Tardies (Lower Campus)

The first bell rings at 8:00 a.m. A student is considered tardy if he/she is not in class at 8:05 a.m. when the second bell rings. A student who arrives after 8:05 a.m. should report to the office to sign in. A student may not be admitted to class without proper authorization. Tardies will be excused with a medical excuse.

Tardies (Upper Campus)

The first bell rings at 7:57 a.m. A student is considered tardy if he/she is not in homeroom at 8:00 a.m. when the second bell rings. If a student arrives before 8:10 a.m., he/she should report to homeroom. A student who arrives at school *after 8:10 a.m.* should report to Student Services. A student may not be admitted to class without proper authorization. Any student who fails to report to student Services when he/she is tardy after homeroom will be issued a class two infraction for cutting class. Tardies will be excused with a medical excuse.

**Medical excuses should be turned in to Student Services at sign in, but no later than seven days following the tardy. After seven days, tardies must be excused by an administrator.

Third unexcused tardy- Twenty-five minute morning detention.

- Excused tardy is defined as illness with a doctor's excuse or medical and dental appointments with a doctor's excuse.
- Tardies are cumulative per nine weeks and start new every nine weeks or after a detention is served.

Dismissals (Lower Campus)

A student requesting early dismissal from school must bring a written request to be presented to the teacher at time of requested dismissal. The written request for early dismissal must include:

- the student's name,
- the date and time of the dismissal,
- the reason for the dismissal,
- the signature of parent or guardian.

The student then will be permitted to go to the office to sign out. Before the student leaves school, he/she must make arrangements with the teacher(s) for any missed tests or assignments.

Parents and students are encouraged to keep absences, dismissals, and tardies to a minimum. We ask that all appointments be scheduled after school hours. Adherence to the attendance policies teaches responsibility and promotes continuity in the classroom.

Dismissals- Upper Campus

Students are encouraged to keep unnecessary dismissals (i.e. haircut, lunch, shopping, forgotten materials, vacation/out of town) to a minimum. Excessive dismissals will be monitored and parents will be notified. A student requesting early dismissal from school must bring a written request to be presented to their class period teacher at the beginning of the class. Students should bring this request to Student Services when signing out. Parents may also send an email to the Student Services administrative assistant as early as possible on the day of dismissal. The written request for early dismissal must include the student's name, the date and time of the dismissal, and the reason for the dismissal. A student may only be dismissed by a phone call in the event of an emergency or illness.

The student

- shows a written request to the dismissing subject teacher and all subject teachers whose classes will be missed.
- makes arrangements with the teacher(s) for any missed tests or assignments.
- signs out before leaving school in Student Services, and returns the written request to Student Services.

Make-up Work

Students are responsible for securing information and assignments given during their absence. Arrangements for all make-up work must be made on the day the student returns. Please refer to each teacher's classroom policy for making up work. In the event of an extended absence requiring large amounts of make-up work, arrangements should be made with the Guidance Office. See "Requests for Homework Assignments."

BOOKS

Most books are property of the school. Although a certain amount of wear and tear is expected, the student is responsible for taking care of the books. When excessive damage or writing in or on a book occurs, the student will owe an additional fee at the end of the year. All textbooks must be covered with book covers.

CARS/PARKING LOT

Driving at OPS is a privilege that may be revoked if drivers display unsafe practices. All drivers are subject to the South Carolina laws governing the use of motor vehicles. Student drivers must park only in their designated areas. Students found parking in an unauthorized area may lose their parking privileges. Students are not allowed to return to their cars before the end of the school day except with written permission from the office. If a student is in the parking lot without permission, he/she will be considered in an unauthorized area without permission/supervision. Sitting in parked cars is prohibited at all

times. Loud music and loitering are not allowed. Roller skates, roller blades, and skateboards are not permitted on campus and the parking lot.

Student cars must be registered in the Student Services' office and must be identified by an OPS driving permit each year. The cost of the permit is \$5. Failure to display the parking permit will result in detention and/or other disciplinary actions. No visitors will be allowed in the parking lot during or after school unless approved by the administration.

NOTE: Drivers are responsible for the actions of their passengers while driving on campus. Orangeburg Prep is not responsible for any damages, thefts, or other losses incurred on any vehicle that is parked on Orangeburg Prep property at any time.

CELL PHONE/TELEPHONE/ELECTRONIC EQUIPMENT

The use of electronic communications and devices is a privilege, not a right. Inappropriate use will result in disciplinary action by school officials and/or canceling those privileges. Use of electronic communications at school must be in support of education and research consistent with the educational objectives of Orangeburg Preparatory Schools, Inc.

The office telephone may be used by students for emergencies and then only by permission from a teacher or staff member. Students may possess personal cellular telephones in school as follows:

- Personal communication devices are not permitted to be used in locker rooms or rest rooms.
- The use of air pods and similar devices is not permitted.
- Cell phones are not allowed in the lunch room or the library.
- No cell phone usage for grades 1-5 during school hours. Phone must be kept in the student's book bag and not visible with all sounds off.
- Cell phone usage for grades 6-8 may be limited during school hours. Phones are restricted to the student's locker or book bag with all sounds off and may only be used under a teacher's discretion.
- Cell phone usage for grades 9-12 may be limited during school hours. Phones are restricted to the students' lockers or book bag with all sounds off and may only be used under a teacher's discretion. Cell phones can only be used between classes at the locker.
- Students are not allowed to take pictures, videos, or utilize social media of any form unless under the instruction of a teacher for educational purposes.
- Parents and students should understand that possession of cell phones at school could pose a risk of loss or theft. We encourage students to properly label their devices and take steps to keep them safe. The school will not be liable for lost or damaged devices.

The following violations will be enforced. *Cell phones will not be held overnight or over weekends/holidays.*

- **First offense:** Loss of cell phone until the end of the day. A Level I detention will be issued (must be signed by parent) and will serve as notification to parents.
- **Second offense:** Loss of cell phone for two school days starting when the cell phone gets confiscated. Students may pick up the cell phone from student services at the end of the first day. Students must leave the cell phone in student services at the beginning of next day and pick it up at the end of the day. A Level II detention will be issued (must be signed by parent) and will serve as notification to parents.
- **Third offense:** Loss of cell phone for one week. Students must leave his/her cell phone in student services at the beginning of the day and pick it up at the end of the day. A Level III detention will be issued (must be signed by parent) and will serve as notification to parents.
- **Fourth offense:** Loss of cell phone for the rest of the school year. A conference will be scheduled with the student and parent. Students may not bring a cell phone to school.

CHILD ABUSE / NEGLECT

Teachers of Orangeburg Preparatory Schools are classified as State Mandated Child Abuse and Neglect Reporters. If a case of abuse is evident, they are **required** to report to the Orangeburg County Department of Social Services or county in which the child resides.

CONFERENCES

Parents wishing to schedule a conference with multiple teachers, counselors, or the administration should telephone the office. Parents are asked not to interrupt homerooms or classes. Teacher conferences should be scheduled directly with the teacher. Parents who wish to meet with administration should contact the office. Appointments should be scheduled in advance by students who wish to see the Head of School or Administration. Waiting for a conference which has not been arranged will be no excuse for missing a class. See the calendar for scheduled conference days. However, a conference may be scheduled at any time during the year.

DEVOTIONALS / PLEDGE

Daily Christian devotionals of a non-sectarian nature, the pledge of allegiance, and the pride pledge will be presented at various times. Participation is not mandatory; however, silence and an attitude of respect are required during this time.

DISCIPLINARY CODE

Through consistent and loving encouragement and correction, students learn to abide by school rules. Rules are made very clear at the beginning of the school year. Classroom management is handled by each individual teacher. In order for effective learning to take place, the school provides rules and regulations which students must obey. Every student has certain rights, but if the learning atmosphere of a classroom or the school is disrupted, then the student will lose his/her rights and appropriate disciplinary action will be taken by the teacher and/or administration.

Most of the time the teacher will handle individual disciplinary problems. The teacher is in charge of all classroom discipline and must be respected. Other students in the class must also be treated with total respect.

One of the most important lessons education should teach is discipline. While it does not appear as a subject, it underlies the whole educational structure. It is the training that develops self-control, character, orderliness, and efficiency. It is the key to good conduct and proper consideration for other people.

Orangeburg Prep does not engage in corporal punishment.

All disciplinary infractions and consequences apply to school property and school-sponsored events. Consequences of disciplinary infractions will be recorded and will impact eligibility for one school year.

DISCIPLINARY INFRACTIONS

CONSEQUENCES ARE AT THE DISCRETION OF THE HEAD OF SCHOOL

Level One Infractions

Level One Infractions are to be handled by the classroom teacher in a manner deemed appropriate by the faculty member. These infractions will be recorded by the classroom teacher and the parents notified. Level One Infractions include but are not limited to the following: accumulation of tardies, chewing gum, being unprepared for class, no homework, unsigned papers, unsigned detentions, dress code violations, first offense cell phone violation, and failure to display a parking decal. Students will have two days to return forms or other papers requiring parent's signature. When a student receives excessive Level One detentions, the classroom teacher will contact the parent by phone or conference to resolve the problem.

Consequences of Level One Infractions:

Level One Infractions may result in a 25 minute early morning detention or after-school detention at the discretion of the teacher with advanced notice. If a student fails to show for a Level One detention, the student will be issued a Level Two detention.

Level Two Infractions

Level Two Infractions will be issued by the classroom teacher. These infractions include but are not limited to the following: any disruption to the learning environment, talking out of turn, classroom/assembly interruptions, horseplay, disrespect or disregarding a teacher's instruction, second offense cell phone violation, disrespect or disregard for another student or another student's property, copying homework, eating at an inappropriate time, unauthorized use of electronic devices, not reporting to the appropriate classroom regardless of intent, failure to sign in or out, cursing, and public display of affection. If a student fails to show for a Level Two detention, the student will immediately be assigned Level Three work detention.

Consequences of Level Two Infractions:

Level Two Infractions may result in a 50 minute early morning detention or other assigned punishment.

Consequences of a Level Two Infraction may also include multiple days of work detentions. The signed detention or a phone call if warranted will serve as notification to the parent.

Level Three Infractions

More serious than Level Two Infractions, Level Three Infractions include but are not limited to the use of profane, abusive, or suggestive language/gestures, cursing, lying, stealing, cheating, plagiarism, leaving campus without proper authorization, forgery, third offense cell phone violation, physical and verbal harassment (which includes bullying as stated in our anti-bullying pledge), fighting, a student's presence in an unauthorized area without permission, inappropriate use of social media, and violation of internet policy. Students who feel they have been harassed need to notify the appropriate faculty or administrator immediately.

Consequences of Level Three Infractions:

These infractions will be handled by the administration. Consequences include but aren't limited to multiple days of work detentions, Saturday detention, or suspension. In addition the student may not participate in any extracurricular activities for the duration of a suspension including the afternoon or evening the day(s) of the suspension.

The consequences will affect participation in extra curricular activities such as, but not limited to, NHS, NJHS, and May Day. These infractions are severe and punishment will be severe. Parents will be notified immediately by the administration.

Level Four Infractions

Clearly the most serious, Level Four Infractions will be handled by the administration. The consequences will affect participation in extra curricular activities such as, but not limited to, NHS, NJHS, and May Day. These infractions include but are not limited to disrespect for faculty and staff, abuse of school property, assault, vandalism, repeated physical and verbal harassment, sexual harassment, possession or use of tobacco or vapes, possession and/or use of drugs or alcohol, theft, arson, inappropriate use of social media, and possession of weapons. Pistols, rifles, and bomb threats are expressly prohibited. *Active members currently on the Orangeburg Prep Sporting Clays Team must have their cased shotguns inside an attended or locked motor vehicle on Orangeburg Prep property.* Students who have been sexually harassed need to notify the Administration immediately.

Consequences of Class Four Infractions:

Because these actions are serious enough to require immediate administrative action, punishment will be severe resulting in suspension, Saturday detention, or expulsion. In addition the student may not participate in any extracurricular activities for the duration of a suspension, including the afternoon or evening the day(s) of the suspension.

These infractions may result in immediate removal of the student from school and possible intervention of law enforcement authorities. The administration will inform the student of the appropriate disciplinary action in a conference with both the student and parents.

Expulsion

After the third level III or IV infraction in one school year, the student will be expelled. A student who is expelled may request a hearing before the Board within three (3) days.

Saturday Work Detention

Saturday work detention is from 8:00 a.m. to 11:00 a.m. scheduled at the convenience of the school. The student should come dressed prepared to work inside or outside the school grounds.

**Failure to report to Saturday detention is a major infraction and consequences may include suspension. Detention takes precedence over all other extracurricular obligations to include jobs and vacations/trips out of town.*

LOWER CAMPUS DISCIPLINE POLICY

Discipline is a community responsibility, and all faculty and staff contribute to maintaining standards for student conduct. However, it is the classroom teacher who is the driving force for school-wide discipline since students spend most of their time in the classroom. Teachers make clear their academic and behavioral expectations for students in their classes, and teachers hold students accountable for those expectations using the best practices of classroom management. The teacher's unique relationship with each student is the foundation for maintaining discipline in the classroom.

Teachers are expected to use their best judgement when working with students. Issues of classroom Management such as, but not limited to, socializing in class, class disruption, and disrespect to peers or teachers, may be handled by the teacher at their discretion. In such cases where the student has not responded to the teacher's corrective measures, they may refer the student to the Lower Campus Administrator.

MINOR INFRACTIONS

Any violation of the school's expected behavior for students at school and during school activities is considered to be an infraction. Minor Infractions are deemed to be less offensive than major infractions but are still considered unacceptable from a member of the school community. Examples of minor infractions include but are not limited to the following:

- Disrespect toward persons or property
- Inappropriate clothing
- Being disruptive in the classroom, library, assembly, or any other campus activity
- Lying, deceit, or any other dishonest behavior
- Profanity

MAJOR INFRACTIONS

There are certain fundamental policies and expectations at OPS that when violated are considered Major Infractions. A Major Infraction is a very serious offense. The following are examples of Major Infractions (the list is not all-inclusive):

- Inappropriate use of social media
- Harassment and bullying
- Verbal, physical or sexual harassment or abuse of a student by peers. This includes interactions that are in person, online, or via phone. Posting videos/photos of peers with or without their consent to do harm is considered harassment.
- Threats or references to school violence
- Cheating or plagiarism
- Willful destruction of property belonging to OPS, its personnel, or another student
- Stealing
- Possession or use of any kind of weapons on campus

POSSIBLE CONSEQUENCES FOR INFRACTIONS

While it is not possible to list all possible consequences for behavioral infractions, below is a list of possible consequences that may occur. In each individual case, the Lower Campus Administrator in collaboration with the Head of School considers the individual student and the OPS community. In all cases, OPS strives to be firm, fair, and consistent when assigning consequences.

DETENTIONS

After-school detentions are to be served when convenient for the teacher who assigned it. Students' schedules are not considered when scheduling detention.

All-day detentions may be given for more serious infractions. The student will spend the day at school under the supervision of an adult and will work on class assignments only. Teachers may visit the student to give guidance on any work. The student will bring his or her own lunch and will not be allowed to socialize with other students for the duration of the detention. Students will not be allowed the use of cell phones, computers, or any other electronic devices while serving all day detention. In addition the student may not participate in any co-curricular activities for the duration of the all-day detention, including the

afternoon or evening the day(s) of the detention.

If a student fails to appear for an assigned detention, a second detention is assigned.

SUSPENSION

Suspension is a possible consequence if a student commits a Major Infraction or exhibits a pattern of violating behavioral expectations. Suspension will also be noted on a student's record.

EXPULSION

Expulsion is a possible consequence for those situations in which a student exhibits a clear disregard for the behavioral expectations of the OPS school community. This can be demonstrated by a continuous pattern of infractions, major or minor, or it can be a single egregious act that threatens or violates the communities shared values, like bringing a weapon to school. The decision to expel a student rests solely with the Head of School.

SCHOOL CLIMATE

All students have the right to an education in a positive environment free from disruptions which interfere with teaching and learning activities and free from discrimination or harassment based upon gender, race, national origin, religion, or disability. Orangeburg Preparatory School provides a positive environment for learning. All members of our school community are encouraged to achieve their personal best and work collaboratively.

BEHAVIOR EXPECTATIONS

Attentive Listening: Listen with your ears, eyes, and hearts. Pay close attention to one another's words and feelings. Give each other caring, respect, and consideration.

Appreciation– No Put-Downs: Treat others kindly and state appreciation for their unique qualities. Avoid negative remarks, name-calling, hurtful gestures, and behaviors.

Mutual Respect: Be respectful of everyone and their rights, needs, differences, and property. Do not use gossip or negative names.

BE RESPONSIBLE

- Come to class on time. All kindergarten through fifth grade students should be in the classroom when the tardy bell rings at 8:05 am.
- All students must be accompanied to the office to sign in if they enter the school after the 8:05 am tardy bell.
- Use the designated bathrooms properly and help keep them clean.
- Show respect for your school. Help keep the school clean and pick up litter.
- Students should discuss after school plans with their parents before they leave in the morning. The office telephone is available only for emergencies.
- Jackets, sweatshirts, lunch boxes, and backpacks should have the child's name labeled in case there are lost.

BE KIND TO EACH OTHER AND RESPOND APPROPRIATELY WITH ALL SCHOOL STAFF

- Use appropriate school language. Swearing is not permitted.
- Party invitations are not to be distributed at school unless the entire class is invited.
- Playground games are open to all students who are interested in participating.

BE SAFE

- Do not verbally or physically hurt other students.
- Walk, do not run, in the hallways and buildings.
- Obey the playground rules.
- No weapons or dangerous items, including pocketknives, near or at school.
- Toys, collections, cards or items that are distracting to the learning process are not to be played with during school hours.
- Cell phones are not to be used during school hours. Cell phones will be taken if students are caught using them.
- Alcohol, tobacco, drugs, and drug paraphernalia are not allowed at school.

DRESS CODE (LOWER CAMPUS)

The basic responsibility for the appearance of the students of OPS rests with the parents and the students themselves. Students must be well-groomed at all times. Students' clothing and hair should be neat and clean. **All students must follow the uniform dress code every school day except on designated dress-down/spirit days. See the OPS Uniform Quick Guide.**

Clothing and appearance that disrupt the educational process by drawing attention to the wearer will not be allowed. Our goal is to make sure our students realize there are traditional and expected standards of dress for particular institutions, circumstances, and occasions, and they should distinguish suitable attire for each. Choosing appropriate clothes is part of the responsibility and decision-making incorporated in an educational institution. Every effort will be made to enforce the dress standards across the board and to be as fair as possible to everyone. **The following guidelines must be followed during dress-down/spirit days and provide guidance for general appearance:**

1. No vulgar, obscene, or otherwise inappropriate symbols, language, art, or wording will be permitted on clothing. Any endorsement of any alcoholic beverage, drug, or tobacco products will not be permitted on clothing.
2. Skirts, blouses, dresses, and shorts are expected to be modest and not provocative. Short athletic shorts are not allowed at any grade level. Long gym shorts are allowed.
3. Tight, torn, ragged, or frayed pants/skirts (including jeans) are not acceptable. Pants, skirts, and jeans must be worn at the normal waistline.
4. All clothing must be neat, fit properly, and be in good taste.
5. Hats, caps, toboggans, or hoods must not be worn in the buildings at any time. This includes both boys and girls.
6. Proper shoes must be worn at all times for health and safety reasons. Heeleys, cleats, camo footwear, army style boots, and hunting boots are not deemed proper. *All clogs and sandals must have a strap around the heel.* Flip-flops of any type are not allowed.
7. Boys' hair must be neatly combed and clean. Appropriateness will be determined by the administration. You will have one day to correct this behavior.
8. Girls are allowed to wear earrings in moderation. Boys are not allowed to wear earrings on campus or at any school-sponsored event. Students are not allowed to wear tongue rings of any type. Neither boys nor girls are allowed to wear any additional visible body-pierced jewelry.
9. Visible tattoos are not allowed on campus or at any school-sponsored event except temporary OP logo tattoos.
10. Bare midriff, strapless, halter, and spaghetti strapped tops/dresses are not allowed.
11. Undergarments (boys/girls) must not be visible at any time.
12. Camouflage (of any color and including digital camouflage) pants, shirts, skirts, or boots will not be allowed.
13. Special dress or costume may be worn only for special occasions when approved by the administration. Attire must be in keeping with the dress code.

A written warning will be sent home to students on the first offense of a dress code violation. All students are reminded if school is missed because of a dress violation, then the time will be unexcused. Dress code violations may result in detention or dismissal from school.

SCISA related events could require students to wear collared shirts/dress pants, or dresses.

DRESS CODE FOR GRADES 6-12

The basic responsibility for the appearance of the students of OPS rests with the parents and the students themselves. Students must be well-groomed at all times. Students' clothing and hair should be neat and clean. **All students must follow the uniform dress code every school day except on designated dress-down/spirit days. See the OPS Uniform Quick Guide.** Clothing and appearance that disrupt the educational process by drawing attention to the wearer will not be allowed. Our goal is to make sure our students realize there are traditional and expected standards of dress for particular institutions, circumstances, and occasions, and they should distinguish suitable attire for each. Choosing appropriate clothes is part of the responsibility and decision-making incorporated in an educational institution. Every effort will be made to enforce the dress standards across the board and to be as fair as possible to everyone. This dress code is effective on the first day of school and during exam days. **The following guidelines must be followed during dress-down/spirit days and provide guidance for general appearance:**

1. No vulgar, obscene, or otherwise inappropriate symbols, language, art, or wording will be permitted on clothing. Any endorsement of any alcoholic beverage or tobacco products will not be permitted on clothing.
2. Skirts, blouses, dresses, and shorts are expected to be modest, not provocative, and the length should be no shorter than the mid-thigh.
3. Torn, ragged, or frayed pants, skirts, or jeans are not acceptable. Pants, skirts, and jeans must be worn at the normal waistline. Boys must wear belts with pants/shorts that have belt loops.
4. No leggings allowed except with a skirt, dress, or tunic that is no shorter than midlength. Athletic leggings are not allowed.
5. All clothing must be neat, fit properly, and be in good taste.
6. Special dress or costume may be worn only for special occasions when approved by the administration. Attire must be in keeping with the dress code.
7. Hats, caps, toboggans, visors, or hoods must not be worn at any time in the school buildings during the school day except on special dress days.
8. Shoes with skates, cleats, camouflage, or army-style boots are not deemed proper.
9. Boys' hair must be neatly combed and clean. Boys' hair must be off the collar and above the eyebrows. Appropriateness will be determined by the administration. You will have one day to correct this.
10. Boys side burns will not exceed the lower lobe of their ears.
11. Beards, moustaches, and goatees are not allowed. Boys must be clean shaven.
12. Unnatural hair colors or hair styles are not allowed.
13. Girls are allowed to wear earrings in moderation. Boys are not allowed to wear earrings on campus or at any school-sponsored event. Students are not allowed to wear tongue rings of any type. Neither boys nor girls are allowed to wear other visible piercing of any type (i.e. nose rings, lip rings, chin rings, eyebrow rings, etc.).
14. Visible tattoos are not allowed on campus or at any school-sponsored event except temporary OPS tattoos.
15. Bare midriff tops are not allowed.
16. Strapless, backless, tank, halter, t-back, spaghetti-strapped, and cut-out tops/dresses must be covered by a sweater, jacket, or shrug.
17. Undergarments (boys/girls) must not be visible.
18. Camouflage (of any color including digital camouflage) pants, shirts, skirts, shoes, or boots will not be allowed.

19. Athletic shorts (i.e. cheerleading, mesh, nylon, soffe) and warm-up/sweat pants are not allowed.
20. Boys must wear a collared shirt and tie for school pictures.
21. Athletic jerseys are not allowed except for OPS jerseys on designated days.
22. Cheerleading uniforms may be worn at the discretion of the administration.

Consequences of Dress Code Violations

Immediate action and issuance of a detention will be taken in accordance with the dress code (i.e. remove cap, change clothes, shave, zip up a jacket).

Any student cited for dress code violations may be required to do the following:

1. Borrow items (belts, razor, etc.) from Student Services or another student.
2. Go home and change into appropriate attire after getting verbal parental permission at the Student Services office. The parent will then need to email or send a signed note to Student Services that they have given verbal permission for their child to leave school.
3. Have a parent bring appropriate attire to school.
4. Haircut/belt violations will be given one day to correct.

All students are reminded if a class is missed because of a dress violation, the time will be unexcused. Dress code violations may result in detention and/or dismissal from school.

Field Trip, Awards Day, and SCISA Student Activities Dress Code

Unless at the discretion of the teacher, *boys* must wear long dress pants, collared shirts, and dress shoes. *Girls* must wear skirts/pants with a blouse or a dress and dress shoes. Sweaters, shrugs, or jackets must be worn over all sundresses. Shorts, t-shirts, tennis shoes, jeans/jean skirts, or flip flops are not allowed. No camouflage coats, shoes, etc. can be worn on a field trip.

Consequences of Field Trip, Awards Day, and Other Special Assemblies Day Dress Code Violation

Students will not be allowed to participate if not wearing appropriate attire. Students will remain at school and attend all classes. On Awards Day, students will be issued a Level I detention and will not be able to participate in the Awards Day program in May.

Note: SCISA related meetings/conferences could require students to wear ties/jackets/dresses.

Some field trips may require different dress. Teachers will notify students of any changes.

EMERGENCY CARE

Orangeburg Prep has a full-time school nurse on lower campus who is able to provide medical treatment to ill or injured students. If necessary, the nurse may assist students at the upper campus.

The following procedures will be used for the caring of sick or injured students:

1. The teacher will remain with the injured child (if he cannot be moved) and send for the proper administrator or member of the office staff.
2. If the child can be moved, he will be brought to the office immediately. A teacher will accompany him.
3. The administrator or member of the office staff will determine the procedures to be followed from this point.
4. If it appears that non-professional care will remedy the situation, this help will be provided.
5. If it is deemed necessary to contact the parents, this will be done by the office staff.
6. The responsibility for getting the child home must be assumed by the parent.
7. If contact with the home cannot be established immediately when a serious accident occurs or when a child becomes alarmingly ill, medical services will be summoned or an ambulance will be called to take the child to the emergency room of the nearest hospital or to the nearest doctor available.

Medication / Health

All students must have a current South Carolina Certificate of Immunization on file in the school office before their first day of school.

Students should not possess any medications during the school day without approval from the administration. Emergency medication (Benadryl, inhalers, Epipens, may be carried by the student with proper documentation from a physician and approval from the administration. All medication to be dispensed at school must be coordinated through the office. A Medical Permission Request Form must be signed by both the physician and the parent. This form must be brought to the office. **NO OVER-THE-COUNTER MEDICATIONS (i.e. TYLENOL, TUMS, ETC.) WILL BE PROVIDED WITHOUT WRITTEN PARENT CONSENT.**

If a child's temperature reaches 100 degrees, parents will be notified. If a child's temperature reaches 101 degrees or greater, the child must be picked up immediately from school. **The child may return to school when the temperature remains normal without medication for 24 hours. Children need to be diarrhea free and/or vomit free for 24 hours before returning to school.**

Children who have symptoms of pink eye should not come to school. Once a child has been treated by a physician, he/she will be allowed to return to school.

OPS has a No Nit Policy which states, *"The exclusion of a child from school until all head lice, lice eggs (nits), and egg cases have been removed. Upon the return of the child to school, he/she will be checked by the office before returning to class."*

When the school deems it necessary for a student to be dismissed due to illness, parents are expected to pick up their child in a timely manner.

FIELD TRIPS

All students represent Orangeburg Prep on field trips and should demonstrate appropriate behavior and dress. See field trip attire under dress code. A student who chooses not to attend a field trip is expected to be in school. Absences will be unexcused without medical documentation. Siblings are not allowed to attend field trips. All of the above applies to the senior class trip. All extra-curricular travel will be done as a group. Signed permission slips will be required. A student to approved chaperones or OP faculty ratio will typically be 10:1. Chaperones should ride on the bus, space permitting.

FOOD / LUNCH (UPPER CAMPUS)

Students may eat breakfast during homeroom or snacks between classes. After 8:10, no more food or drink will be allowed in the classrooms except for on special occasions.

All students will eat lunch in the canteen. Students are not allowed to leave for lunch. Students should bring lunch from home if they do not order from the canteen. Seniors may eat in the Senior Courtyard. No food or drink is to be taken elsewhere. Water bottles are allowed in classrooms.

If a student arrives tardy, lunch must be ordered through Student Services upon signing in. If a student is dismissed and has ordered lunch, the order should be cancelled through Student Services when signing out or the student will be responsible for payment of the lunch order that was not cancelled. Parents/other visitors are not allowed to deliver lunches in the canteen parking lot. Lunches must be delivered to Student Services.

Students should use restroom facilities by the weight room in the gym. All other buildings are off-limits during lunch unless supervised by a teacher.

Students are not allowed to go to the canteen to purchase food or drinks during the school day.

No outside food delivery allowed like Grubhub, DoorDash, etc.

HALL PASSES

Students should be in the halls only at the beginning and close of school and while moving from one class to another class unless they have special permission or special duties that require them to be there. Students in the halls during class time must have passes. Students are asked to be courteous at all times and to keep to the right when moving in the halls. Running and shouting are never permitted.

HONOR ROLL

The Honor Roll will be published at the end of each grading period and at the end of each semester. All subjects (academic and non-academic) are used to determine the honor roll. To be eligible a student must meet the following requirements:

Grades 1-5:

All A Honor Roll is compiled every nine weeks to recognize those students who will be composed of students making all A's in each course.

The A/B Honor Roll is compiled every nine to recognize those students who achieve a B or above in each course. Satisfactory grades of B or above must be maintained in non-academic courses to be listed on the Honor Roll.

End of the Year All A Honor Roll is compiled at the end of the year to recognize students who achieve a 90 or above in all courses for all 4 nine weeks individually.

End of the Year A/B Honor Roll is compiled at the end of the year to recognize students who achieve an 80 or above in all courses for all 4 nine weeks individually.

Grades 6-12:

All A Honor Roll (4.0 and above GPA for each course) is compiled every nine weeks to recognize those students who achieve an A in each course.

Honors courses and Advanced Placement courses will be weighted in the determination of the Honor Roll.

The A/B Honor Roll (3.0 and above for each course) is compiled every nine weeks to recognize those students who achieve a B or above in each course. Satisfactory grades of B or above must be maintained in non-academic courses to be listed on the Honor Roll. A student must be enrolled in a minimum of four academic courses to be on the Honor Roll. Semester and yearly honor rolls will be determined by average.

LOCKERS

Lockers are available for students to be used solely and exclusively for school-related materials. Combination locks will be provided by the school with a \$5 rental fee to cover the locker and lock. Only school issued locks will be allowed. Lockers should be kept neat and clean. The administration has the authority to inspect lockers at anytime. The school will not assume responsibility for any items in an unlocked locker.

LOST AND FOUND

The lost and found accumulates a large supply of jackets, sweaters, backpacks, folders, etc. during the course of one school year. Parents and students are welcome to come before or after school and search for their missing items. All items left at the end of each semester are given to charity. Please put your child's name in all jackets, sweaters, etc.

PARTIES (LOWER CAMPUS)

Class: No surprise parties can be allowed. Grade mothers plan and carry out designated parties and treats during the year. These parties should be kept to a minimum in order to allow more time for academic instruction. No off-campus parties are allowed.

PERSONAL PROPERTY

The only time students should bring toys, games, or other electrical devices, etc. to school is when their teacher instructs them to do so. (i.e.: Show and Tell). THE SCHOOL WILL NOT ASSUME RESPONSIBILITY FOR ANY ITEMS BROUGHT TO SCHOOL.

PETS

Pets are not allowed at school. We have some students who are afraid of and/or allergic to animals. For the safety and concern of all in attendance at our home matches, meets, and games, please do not bring pets (includes all sporting events). They will not be allowed in the gym or fenced areas.

REPORT CARDS

Lower Campus: Report cards will be issued quarterly to students in grades 4K-2nd Grade whose financial obligations to Orangeburg Prep are met. These report cards must be signed by parents and returned by the end of the second day to the teacher who issued them. Failure to return them by this time will result in a consequence. Report cards for grades 3rd-5th will be posted quarterly online through Gradelink provided financial obligations are met. Parents can determine their child's academic progress by accessing Gradelink or by contacting the teacher.

Upper Campus: Report cards will be available quarterly online on Gradelink provided financial obligations are met. If financial obligations are not current, the Gradelink account will be locked. Parents are responsible for checking report cards on Gradelink.

REQUESTS FOR HOMEWORK ASSIGNMENTS

Homework assignment requests will not be accepted through Student Services. Students are expected to check Gradelink. If textbooks are needed, please call the office by 9:00 A.M. The textbooks/work may be picked up at the end of school in the office.

RIGHT TO SEARCH

Orangeburg Preparatory Schools, Inc. reserves the right to search the person, property, lockers, or automobile of any student on campus or attending a school-sponsored event at any time there is reason to believe that the student may be concealing illegal or potentially dangerous objects, instruments, chemicals, drugs, alcohol, or other substances. It also reserves the right to confiscate any objects, instruments, chemicals, drugs, or substances it believes may be illegal or potentially dangerous. This right is reserved to protect the student body at large and will be employed with discretion. Attendance at Orangeburg Preparatory Schools, Inc. is contingent on the student's and parent's agreement to the rights of Orangeburg Preparatory Schools, Inc. as stated above.

SAFETY PROCEDURES/WEATHER

Fire drills are necessary for the safety of the student, staff, and faculty. Everyone should know the specific directions for reaching a point of safety from those areas of the school building in which he or she may be located. Specific information for fire drills is posted in each room. Tornado drills are practiced and students are taught to assume a protective position in the hall. These drills are especially important during severe weather warnings. Bomb threat, intruder, and other drill procedures are also in place.

Safety of not only students, but faculty, staff, and parents must be considered in times of inclement weather. We have many students and faculty who travel great distances. In times of inclement weather, we ask for your patience and understanding. If you have signed up for text alert, you will receive the first emergency notification. The radio stations BADDOG-105, CATCOUNTRY-105.3, OLDSKOOL-102.9, WORG-100.3, AND WIS-TV 10 will announce a school closing due to severe or hazardous weather conditions. You may also log-on to www.wistv.com or www.orangeburgprep.com and check the news box scroll. We ask that you listen to the stations. If a closing is deemed necessary after school is already in session, an e-mail from the school will be sent to all addresses that are on file. Please do not call the school.

SCHOOL INSURANCE

All students are covered under Orangeburg Prep's Accident School-Time Insurance Coverage.

SCHOOL RING

The wearing of the school ring is a privilege granted by Orangeburg Preparatory Schools and not a right. Juniors currently enrolled at OPS who are passing at least eighteen units, fifteen of which must be academic and including three units of English, will be allowed to order the school ring and may participate in the ring ceremony.

SIGNED PAPERS—TUESDAYS (LOWER CAMPUS)

All forms and signed papers requiring parent's signature must be returned by the end of the second day or disciplinary action will be taken. Students will not be allowed to call parents for signed papers during school hours.

SOLICITATION/DISTRIBUTION OF MATERIALS

No posters, handbills, or printed material of any kind may be displayed, sold, or distributed at any time, anywhere on the Orangeburg Prep campus without the administration's consent. No solicitation of funds or sale of any product for whatever purpose may be made at any time, anywhere on the school's campus without the administration's consent.

STUDENT MESSAGES

Classes cannot be interrupted for student messages or visitors. Please limit messages to emergencies only. Because office personnel are unable to hand deliver messages during the school day, these messages are delivered through the intercom at the beginning of sixth period. Lunches, books, etc. should be taken to Student Services. Parents and visitors are asked not to interrupt classes.

STUDY HALLS (UPPER CAMPUS)

Study hall provides an opportunity for students to prepare academic assignments and conduct research. An atmosphere conducive to learning must be maintained at all times. Students are expected to bring books and necessary materials and to work on assignments independently. Socializing, loitering in the halls, and using electronic equipment will not be permitted. Students leaving study hall must have a pass stating his or her destination. No student will be allowed to leave study hall to go to the computer lab without prior approval and a written pass. Students are not to go to the canteen or gym during study hall.

SUBSTITUTE TEACHERS

Substitute teachers have the same authority as regular classroom teachers and should be accorded the same respect. Students should be aware that all directions given by the substitute teachers should be followed. Disrespect to substitute teachers will not be tolerated. If a substitute issues a detention, detention times may be doubled.

SUPERVISION

School supervision begins at 7:15 a.m. (for early arrival) and ends each day at 3:00 P.M. Parents are responsible for the supervision of their children at all extra curricular events/activities to include sporting events. For safety reasons, children should not be left at extra curricular activities without a designated responsible adult in attendance.

TEACHER REQUESTS

Our goal is to create classes that are balanced academically and socially and to avoid groupings that would distract from the learning process. Requesting specific teachers poses a problem in achieving this balance. All of our teachers are highly qualified and possess their own unique qualities that any child can benefit from.

VISITORS

Parents and other visitors are welcome to visit OPS at anytime with prior administrative approval. Siblings and alumni are welcome to visit OPS. Visitors are asked not to interrupt homeroom, lunch, or classes. All those wishing to see a student or teacher must check in at the office upon arrival and wear a visitor's pass while on campus. Unauthorized visitors will be considered trespassers and asked to leave campus. If you wish to drop off lunch or other items, please bring them to the office. Parents and visitors are asked not to interrupt classes.

**Orangeburg Prep
Uniform Quick Guide
4K-12th Grades**

Items can be purchased online at Lands' End [www.landsend.com/school](http://www.landsend.com/school/SchoolSearch.html?action=landing&selectedSchoolNum=900160359) using the school link: <http://www.landsend.com/pp/SchoolSearch.html?action=landing&selectedSchoolNum=900160359>

BOYS	GIRLS
<p><u>Shirts</u> (<i>must be tucked in at the Upper Campus</i>) Polo: Red, white, gray (short or long sleeve) with OP logo Oxford: White (short or long sleeve) with OP logo</p> <p><u>Pants/Shorts</u> (must be midthigh or longer) Pants: Khaki, gray, or black Shorts: Khaki, gray, or black</p> <p><i>Khaki pants and shorts must be classic cut cotton or poly/cotton. Cargo pants and canvas work-style pants/shorts are not allowed.</i></p> <p><u>Outerwear</u> <i>Any of the following may be worn with an approved collared shirt underneath.</i></p> <p style="padding-left: 40px;">Any OP red, white, or gray pull-over, sweater, fleece, or vest</p> <p><u>Footwear and Belts</u> Socks: Ankle or crew in solid white, red, gray, black, or khaki Shoes: See handbook Belts: Solid brown or black belts are required for pants and shorts with belt loops at the Upper Campus</p> <p><u>Optional</u> Tie (solid red)</p>	<p><u>Shirts</u> Polo: Red, white, gray (short or long sleeve) with OP logo Oxford: White (short or long sleeve) with OP logo</p> <p><u>Pants/Shorts, etc.</u> (must be midthigh or longer) Pants: Khaki, gray, black, or white Shorts: Khaki, gray, black, or white Skirts/Skorts: Khaki, red, gray, black, or approved plaid Jumper: Khaki, gray, approved plaid Dress (short or long sleeve): Khaki, red</p> <p><i>Skirts/skorts must be purchased from a uniform line of clothing. Ruffled, frilly, layered, sheer, or thin tennis skirts and athletic brand skirts/skorts are not approved. They must be midthigh or longer. The styles offered by Lands' End are all approved.</i></p> <p><u>Outerwear</u> <i>Any of the following may be worn with an approved collared shirt underneath.</i></p> <p style="padding-left: 40px;">Any OP red, white, or gray pull-over, sweater, fleece, or vest</p> <p><u>Footwear, Leggings (under skirts/dresses), and Belts</u> Socks: Ankle, crew, and knee socks in solid white, red, gray, black, or khaki Leggings or tights: Solid black or gray Leggings or tights that are torn, see-through, ripped, fishnets, etc., are not approved. Shoes: See handbook Belts: Solid brown or black belts (optional)</p>

LUNCH ROOM INFORMATION FOR LOWER CAMPUS



The Lunch Room serves a hot lunch, loaded baked potato (choice of any or all of the following: butter, sour cream, cheddar cheese and bacon bits), chef salad, grilled chicken breast salad, bag lunch (ham, turkey, bologna or peanut butter and grape jelly) and a grab& go lunch (low-fat strawberry yogurt, cheese stick, fresh fruit, carrots with ranch dip and Goldfish crackers) every day. All of these options include milk, juice, water or

lemonade with free refills on water or lemonade. The price of all options is \$4.00 each which includes sales tax. The bag lunch also includes a chocolate chip cookie and one of the following: fresh fruit, potato chips, cheese stick, strawberry yogurt or carrots with ranch. For the bag lunch, all sandwiches are made on white bread but wheat bread is available. Please write "wheat" on your child's lunch money envelope along with the sandwich type. The sandwiches will be made plain but mayonnaise and mustard are available. The monthly menu is posted on the OPS website: www.orangeburgprep.com. You may pay daily, weekly or monthly. Please put the payment (cash or check) in an envelope with your child's FIRST and LAST NAME on it. Please write on the envelope the dollar amount you are paying, which days you are paying for them to eat lunch and what type of lunch (hot lunch, chef salad, ham sandwich, etc.). Please make checks payable to "The Lunch Room". There will be a \$30.00 service charge for all checks not honored by your bank. If The Lunch Room receives more than 3 NSF checks from a customer, that customer will be on a "CASH ONLY" basis for the remainder of the student's time at OPS.

MENU/PRICE LIST FOR LOWER CAMPUS

Hot lunch, baked potato, salad, grab & go or bag lunch is \$4.00 per day
One week of lunches = \$20.00

*All prices are subject to change due to rising food costs. Parents will be notified by email if changes occur. *
The Lunch Room also offers the following items for purchase:

2% milk 1.00 Low-Fat yogurt 1.00
Low fat chocolate milk 1.00 Carrots w/ ranch 1.00
Apple juice 1.00 Cheese stick 1.00
Lemonade (free refills) 1.00 Fresh baked cookie 1.00
Cup of ice or water .50 Ice cream 1.00 and up
Potato chips 1.00 Goldfish crackers .75
Fresh fruit 1.00 Fruit Gummies .50
Indiv. cup of salad dressing small .50 large 1.00

To keep food costs down The Lunch Room will only provide condiments, napkins, straws, etc. to those students who purchase food from The Lunch Room. Napkins, straws, ketchup, mustard, etc. will not be provided to students who bring lunch from home. Salad dressings will be available for purchase separately.

Grades 4k – 5th : If your child forgets his/her lunch or lunch money for the day, The Lunch Room will issue a lunch voucher for one lunch for that day. There will be a \$.50 service charge for each lunch voucher issued. There will be a limit of three outstanding lunch vouchers. If your child has more than three outstanding lunch vouchers, they will have to call you to bring lunch or lunch money.

Lunch Credit Policy: Parents are responsible for keeping up with lunch credits due to absences, etc. If you are using a credit, please send a note stating the absence date and when the credit will be used.

LUNCH ROOM INFORMATION FOR UPPER CAMPUS

The Lunch Room at the Upper Campus provides a wide variety of lunch options on a daily basis. There will be a hot meal served daily at a cost of \$4.75 per day. *** All prices are subject to change due to rising food costs. Parents will be notified by email if changes occur. *** The monthly hot lunch menu is posted on the OPS website: www.orangeburgprep.com.

The Lunch Room also offers a variety of freshly made sandwiches, salads, wraps and hot food items. These items are available on a daily basis. Please see the “Menu/Price List for Upper Campus” page for a complete list of items available for purchase. Students will order their hot or cold lunch menu items through Google Classroom each morning. Students will not be required to order individual items like drinks, chips, cookies, etc. The cutoff time for ordering lunch each morning is 8:45 a.m. If a student arrives late, they will need to place their lunch order through Student Services if they have not already ordered online. If a student is dismissed and has ordered lunch, the order should be cancelled through Student Services when signing out or the student will be responsible for payment of the lunch order that was not cancelled.

The Lunch Room will only provide condiments, napkins, utensils, etc. to those students who purchase food from The Lunch Room. Salad dressings, ketchup, mustard, utensils, napkins, etc. will not be provided to students who bring lunch from home. The students have the option of paying on a daily basis (by cash or check) or purchasing a prepaid meal card. The meal card is issued for \$10.00 or \$20.00 and can be used for any purchase from a \$1 cookie to a hot meal for \$4.75. If you would like to send more or less than the \$10 or \$20 card, The Lunch Room will issue multiple cards or reduce the amount on the card to reflect the purchase price. The meal card will be marked accordingly for the amount the student purchases each day. The Lunch Room is not responsible for lost or destroyed lunch cards. There will be a secure, supervised location in the cafeteria for the students to keep their lunch cards in if they so desire. The students may pay with cash or check. If paying by check, students will be required to buy a meal card if the check is written for more than one day’s lunch. The Lunch Room will not cash checks. Students should turn in meal card payments to their homeroom teacher during homeroom. If students are paying daily, they can pay for their lunch at the cash register during lunch. Please make checks payable to “The Lunch Room” and write the student’s name on the memo line of the check. There will be a \$30.00 service charge on all checks not honored by your bank. If The Lunch Room receives more than 3 NSF checks, that student will be on a “CASH ONLY” basis for the remainder of the student’s time at OPS. The Lunch Room will NOT issue lunch vouchers, IOU’s, etc. to students in grades 6-12 who forget their lunch or lunch money. Students are not allowed to “charge” their lunch. Please make sure your child has lunch or lunch money every morning or they will have to call you to bring them lunch or money.

MENU/PRICE LIST FOR OPS UPPER CAMPUS

All items are available on a daily basis

*** All prices are subject to change due to rising food costs. Parents will be notified by email if changes occur. ***

HOT MEAL \$4.75 ***SEE MONTHLY MENU ***

INCLUDES 12 oz. TEA OR LEMONADE WITH FREE REFILLS

CHEF SALAD \$4.75

MIXED GREENS, DICED HAM, CHEDDAR CHEESE, TOMATOES, CUCUMBERS, &

CROUTONS WITH CHOICE OF LARGE DRESSING

GRILLED CHICKEN BREAST SALAD \$4.75

MIXED GREENS, MOZZARELLA, PROVOLONE AND ROMANO CHEESES, GRILLED CHICKEN BREAST STRIPS, TOMATOES, CUCUMBERS, & CROUTONS WITH CHOICE OF LARGE DRESSING

SIDE GARDEN SALAD \$3.75

MIXED GREENS, CHEDDAR CHEESE, TOMATOES AND CUCUMBERS WITH CHOICE OF SMALL DRESSING



DRESSING CHOICES: HONEY MUSTARD, RANCH, ITALIAN, CAESAR,
FAT-FREE
ITALIAN, FRENCH OR THOUSAND ISLAND DRESSING

GRILLED CHICKEN WRAP \$4.75
FLOUR TORTILLA WRAPPED AROUND SLICED GRILLED CHICKEN,
MOZZARELLA & PROVOLONE CHEESE AND LETTUCE WITH
CHOICE OF SMALL
DRESSING

HAM & TURKEY WRAP \$4.75
FLOUR TORTILLA WRAPPED AROUND TURKEY, HAM, BACON, WHITE
AMERICAN
CHEESE AND LETTUCE WITH CHOICE OF SMALL DRESSING

FRIED CHICKEN WRAP \$4.75
FLOUR TORTILLA WRAPPED AROUND FRIED CHICKEN BREAST STRIPS,
LETTUCE, CHEDDAR CHEESE AND BACON BITS WITH CHOICE OF SMALL
DRESSING (WRAP IS SERVED COLD)

CLUB SANDWICH \$4.50
THREE TOASTED BREAD SLICES WITH SMOKED HAM, TURKEY, BACON, SWISS
AMERICAN CHEESE, AND LETTUCE WITH CHOICE OF MUSTARD OR MAYO

BAKED POTATO \$3.50
LARGE BAKED POTATO WITH BUTTER, SOUR CREAM, BACON BITS and
SHREDDED CHEDDAR CHEESE

HAM SANDWICH \$2.75
WHITE BREAD WITH SMOKED HAM AND AMERICAN CHEESE WITH CHOICE OF
MUSTARD OR MAYO

TURKEY SANDWICH \$2.75
WHITE BREAD WITH SMOKED TURKEY BREAST AND WHITE AMERICAN CHEESE
WITH CHOICE OF MUSTARD OR MAYO

BOLOGNA & CHEESE SANDWICH \$2.25

PEANUT BUTTER & JELLY SANDWICH \$2.25

*** (Wheat bread is available on request for all sandwiches – please make a note on your lunch order in the morning) ***

FRENCH FRIES \$2.00

*GRILLED CHICKEN SANDWICH \$3.75

PIZZA STICK \$2.00

*CHICKEN FILET SANDWICH \$3.75

*CHICKEN STRIP BASKET \$4.75

(includes two chicken strips,
French fries & tea/lemonade)

MINI CORN DOG BASKET \$4.75

(includes 8 mini corn dogs, French fries & tea/lemonade)

NACHO CHIPS with MEXICAN

CHEESE DIP \$3.75

*includes choice of small ranch or honey mustard cup

UPPER School Lunch Prices

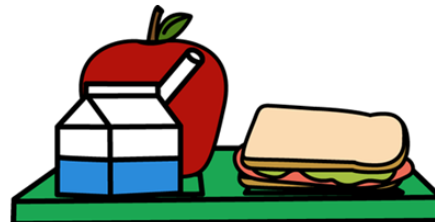

“Small” Chocolate Chunk Cookie \$1.00

“Big” Chocolate Chunk Cookie \$2.00

ICE CREAM \$1.00 and up

POTATO CHIPS \$1.00

FRESH FRUIT \$1.00

CANNED DRINKS \$1.00

DASANI WATER \$1.00

TEA/LEMONADE/WATER/ICE \$1.00 (free refills)

INDIV. CUP OF SALAD DRESSING Small \$.50 large \$1.00

Traffic Pattern 2023-2024

Lower Campus Car Line Procedures



Morning Drop Off

Parents dropping off at the CDC need to make sure they are in the right lane approaching the school. Lower Campus parents will need to be in the left lane. Parents dropping off 4K students need to turn into the parking lot and park at the end closest to the entrance to building A. If you are dropping off both a 4K student and another student in a higher grade level, you will need to drop off your older child/children first. If you are a parent who has children in both the CDC and lower campus, please drop the youngest at the CDC, and then proceed to drop off Lane A. Please review the traffic diagram for the Lower Campus (see diagram below). This information should be shared with anyone who may be picking up or bringing your child to school. Our first concern is the safety of your student. Please move all the way down Lane A (even if your student's classroom is in building B). Faculty will be out in carpool to direct you. All students must be prepared to exit on the right hand side of the car. For your safety, drivers must remain in the car while the students are dropped off. Please do not pull out between cones. You will need to continue to follow the car in front of you to exit. Keep in mind that all students from 5K-5th grades are being dropped off in this manner. It is imperative that all students are ready to exit the car so that we can keep the line moving. Safety is the main objective. Please show patience as we work together to keep our students safe.

Afternoon Pick Up

For afternoon pick up, cars will be stopped between the two crosswalks. The children will come to your car after all cars have stopped.

OPS Lower Campus Traffic Pattern

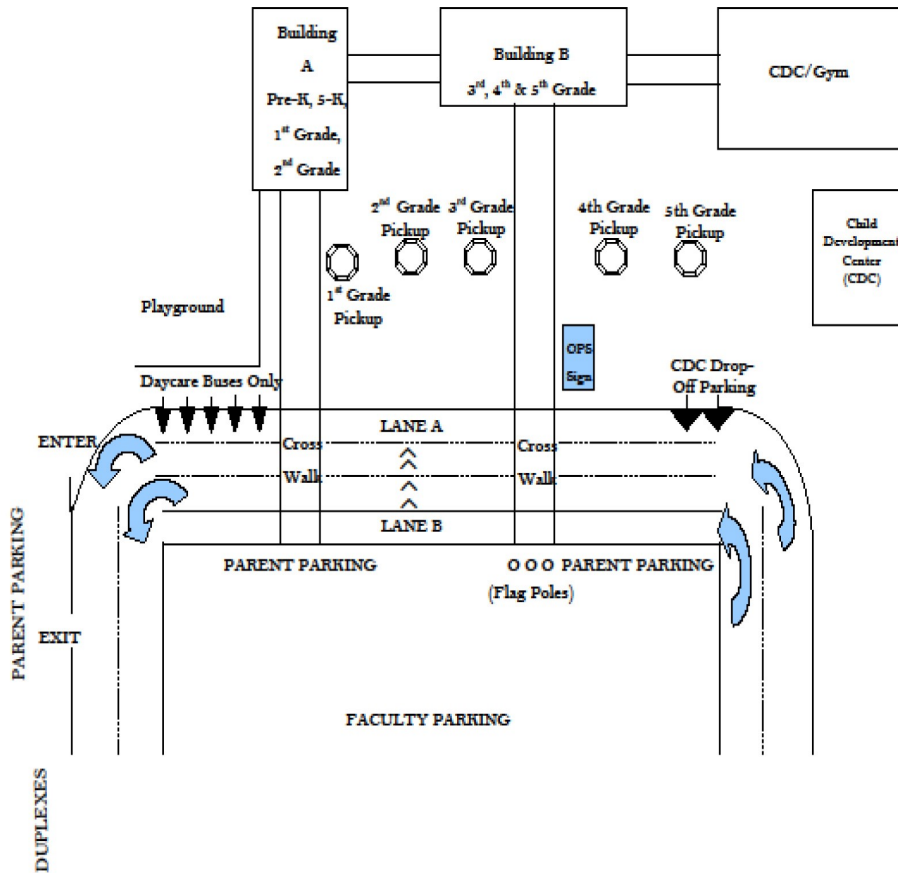

Upper Campus Traffic Pattern

1. The first entrance must be used by parents to drop-off or pick-up students. As you enter around the grassy traffic circle, continue to move forward towards the gym until traffic stops. If no one is in front of you, you need to proceed to the gym area to drop-off or pick up. This will alleviate traffic being backed up on North Road. Once your car comes to a complete stop in the drop-off lane, your child may exit using the right hand side. **Students can only enter or exit cars in the pick-up/drop-off lane (not the moving lane). Please do not block the moving lanes.**
2. After dropping off or picking up, continue to the lower exit. This is the only exit route!
3. Metal poles will prevent cars from driving into the parking lot from the first entrance during drop-off and pick-up hours. In the morning, teachers, students, and parents who wish to park can use the second entrance. Seniors, juniors, sophomores, freshmen, and faculty will park in the designated areas. Parents may park in the faculty/parent parking area near the gym in the afternoon. Please refrain from parking in or driving through the grassy area in front of the school.
4. Anyone parking must use designated crosswalks.
5. In the afternoon, the only entrance is Entrance 1. Entrance 2 will only be used in the morning.
6. When leaving the campus after school, all traffic must follow the painted arrows in the parking lot. Please be sure to view the Upper Campus Traffic Map.



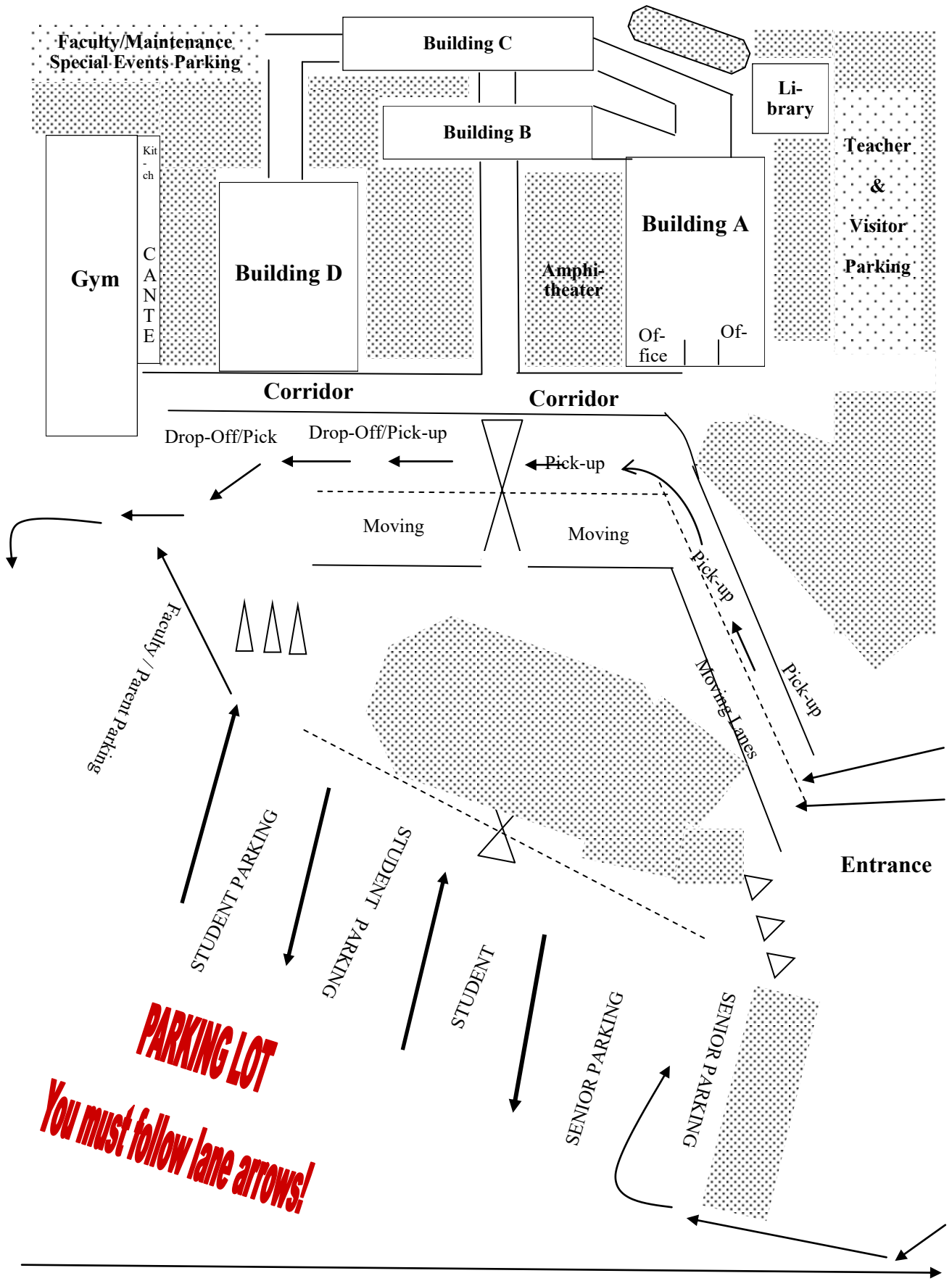

UPPER CAMPUS TRAFFIC PATTERN 2023-2024

UPPER SCHOOL		REGULAR BELL SCHEDULE		MIDDLE SCHOOL	
7:57		First Bell		7:57	
8:01	8:11	Homeroom		8:01	8:11
8:15	9:02	First Period		8:15	9:02
9:06	9:53	Second Period		9:06	9:53
9:57	10:44	Third Period		9:57	10:44
10:48	11:35	Fourth Period		10:48	11:35
11:39	12:26	<i>Fifth Period for Upper</i>	<i>Lunch for Middle</i>	11:39	12:09
12:30	1:00	<i>Lunch for Upper</i>	<i>Fifth Period for Middle</i>	12:13	1:00
1:04	1:05	Announcements		1:04	1:05
1:05	1:52	Sixth Period		1:05	1:52
1:56	2:43	Seventh Period		1:56	2:43
2:45	3:15	Extra Help		2:45	3:15

UPPER SCHOOL		ACTIVITY BELL SCHEDULE		MIDDLE SCHOOL	
7:57		First Bell		7:57	
8:01	8:11	Homeroom		8:01	8:11
8:15	8:59	First Period		8:15	8:59
9:03	9:47	Second Period		9:03	9:47
9:51	10:10	Activity		9:51	10:10
10:14	10:58	Third Period		10:14	10:58
11:02	11:44	Fourth Period		11:02	11:44
11:48	12:32	<i>Fifth Period for Upper</i>	<i>Lunch for Middle</i>	11:48	12:18
12:36	1:06	<i>Lunch for Upper</i>	<i>Fifth Period for Middle</i>	12:22	1:06
1:10	1:11	Announcements		1:10	1:11
1:11	1:55	Sixth Period		1:11	1:55
1:59	2:43	Seventh Period		1:59	2:43
2:45	3:15	Extra Help		2:45	3:15

UPPER SCHOOL		MORNING ASSEMBLY		MIDDLE SCHOOL	
7:57		First Bell		7:57	
8:01	8:11	Homeroom/Report to Gym		8:01	8:11
8:14	8:46	Assembly		8:14	8:46
8:50	9:32	First Period		8:50	9:32
9:36	10:18	Second Period		9:36	10:18
10:22	11:04	Third Period		10:22	11:04
11:08	11:50	Fourth Period		11:08	11:50
11:54	12:36	<i>Fifth Period for Upper</i>	<i>Lunch for Middle</i>	11:54	12:26
12:40	1:12	<i>Lunch for Upper</i>	<i>Fifth Period for Middle</i>	12:30	1:12
1:16	1:17	Announcements		1:16	1:17
1:17	1:59	Sixth Period		1:17	1:59
2:03	2:45	Seventh Period		2:03	2:45
2:45	3:15	Extra Help		2:45	3:15

UPPER SCHOOL		AFTERNOON ASSEMBLY		MIDDLE SCHOOL	
7:57		First Bell		7:57	
8:01	8:11	Homeroom		8:01	8:11
8:15	8:58	First Period		8:15	8:58
9:02	9:45	Second Period		9:02	9:45
9:49	10:32	Third Period		9:49	10:32
10:36	11:19	Fourth Period		10:36	11:19
11:23	12:06	<i>Fifth Period for Upper</i>	<i>Lunch for Middle</i>	11:23	11:55
12:10	12:42	<i>Lunch for Upper</i>	<i>Fifth Period for Middle</i>	11:59	12:42
12:46	1:29	Sixth Period		12:46	1:29
1:33	2:16	Seventh Period		1:33	2:16
2:19	2:43	Assembly		2:19	2:43
2:45	3:15	Extra Help		2:45	3:15

BULLYING AND CYBER BULLYING

Definition of Bullying:

“Bullying is unwanted, aggressive behavior among school aged children that involves a real or perceived power imbalance. The behavior is repeated, or has the potential to be repeated, over time. Both kids who are bullied and who bully others may have serious, lasting problems.

In order to be considered bullying, the behavior must be aggressive and include:

- **An Imbalance of Power: Kids who bully use their power-such as physical strength, access to embarrassing information, or popularity-to control or harm others. Power imbalances can change over time and in different situations, even if they involve the same people.**
- **Repetition: Bullying behaviors happen more than once or have the potential to happen more than once.**

Bullying includes actions such as making threats, spreading rumors, attacking someone physically or verbally, and excluding someone from a group on purpose.”

Source: <http://www.stopbullying.gov/what-is-bullying/definition/>

The Administration is strongly against cyber bullying. The Administration reserves the right to discipline a student(s) for cyber bullying actions taken on campus if the actions are intended to have an effect on another student or the actions adversely affects the well being of a student(s). Cyber bullying involves taunting, threatening, and/or harassing others by the use of the Internet and/or other communication devices.

Bullying Policy for Students:

By signing the OPS Anti-Bullying Pledge, I, the student, agree to:

- Value student differences and treat others with respect.
- Avoid bullying incidents and not be a bully.
- Report honestly and immediately all incidents of bullying to a faculty member.
- Be alert in places around the school where there is less adult supervision such as bathrooms, corridors, locker rooms, buses, lunch-rooms, before or after school, and at any after school event.
- Support students who have been or are subjected to bullying
- Talk to teachers and parents about concerns and issues regarding bullying.
- Work with other students and faculty to help the school deal with bullying effectively.
- Encourage others to discuss bullying issues in the classroom.
- Be a good role model for younger students and support them if bullying occurs.
- Participate fully and contribute to any activity dealing with bullying.
- Acknowledge that whether I am being a bully or see someone being bullied, it is my responsibility to stop or report the activity.

Consequences for students who bully or who do not report or stop bullying activity:

1st Offense: A teacher or staff member will:

- * Assist you with problem solving and issue appropriate consequences.
- * Contact a parent or guardian.
- * Send the student to the office for further discussion (depending on severity).

2nd Offense: A teacher or staff member will (depending on the severity of the offense):

- * Parents will be contacted and a meeting will be scheduled to devise a plan to help change the behavior.
- * Issue appropriate consequences.

3rd Offense: A teacher or staff member will (depending on the severity of the offense):

- * Send you to the office where a suspension will be emplaced.

What to do if you’ve been bullied, or if you’ve witnessed bullying:

- Report the incident to an adult immediately. The sooner it is reported, the more beneficial the consequences, and the more accurate all accounts of what happened. If possible, report it to an adult at school.
- Support/comfort the bullied student.

Bullying Policy for Adults:

By signing the OPS Anti-Bullying Pledge, I, the adult, agree to:

- * Work in partnership with the school to encourage positive behavior, valuing differences and promoting sensitivity to others.
- * Discuss regularly with our children their feelings about school work, friendships, and relationships.
- * Inform faculty of changes in our children’s behavior or circumstances at home that may change a child’s behavior at school.
- * Approach faculty members with a respectful tone.
- * Refrain from approaching other students with any concerns.

- * Notify any adults involved with OPS of the anti- bullying policy.
- * Support OPS in their enforcements of the Bullying Policy

What to do if your child has been bullied or has witnessed bullying:

- * Report the incident to your child's **teacher** immediately. The teacher will take the steps to ensure action is taken.
- * Encourage your child to tell an adult at school of any future incidents so that action can be taken to stop the bullying.
- * Encourage your child to be a role model and positive friend to others.

TECHNOLOGY USAGE

1. Students are to show consideration and integrity when using the computers and the Internet on the OPS campuses.
2. Anyone found tampering with or vandalizing computers and networking equipment will be held responsible for any damages he/she has done.
3. The computers in the labs and in the library are for student and faculty use. If you need to use the computer labs, please notify the computer instructors in advance. This way you can be sure that the lab is available.
4. Anyone caught using a computer and/or the Internet in an unauthorized way will have his/her privileges revoked. Further disciplinary action may be taken.
5. Anyone caught altering or accessing someone else's files without permission will be immediately disciplined.

ANTI-HARRASSMENT

Orangeburg Preparatory Schools is committed to maintaining a school environment free of harassment based on race, color, sex, religion, national origin, sexual orientation, age, or disability. Harassment by administrators, teachers, certified and support personnel, students, vendors, and other individuals at school or at school-sponsored events is unlawful and is strictly prohibited.

Orangeburg Preparatory Schools require all employees and students to conduct themselves in an appropriate manner, with respect for their fellow employees, students, and all members of the school community.

I. DEFINITION OF HARASSMENT

In General. Harassment includes communications such as gestures, jokes, comments, innuendoes, notes, display of pictures or symbols, communicated in any form, including orally, in writing, or electronically via the Internet, cell phones, text messaging or in any other way, that shows disrespect to others based upon a protected class. Legally protected classes include: race, color, religion, nation origin, sex, sexual orientation, genetic information, ancestry, age, handicap or disability, and service in the uniformed military service.

By law, what constitutes harassment is determined from the perspective of a reasonable person with the characteristic on which the harassment is based. What one person may consider acceptable behavior may reasonably be viewed as harassment by another person. Therefore, individuals should consider how their words and actions might reasonably be viewed by other individuals. It is also important for individuals to make it clear to others when a particular behavior or communication is unwelcome, intimidating, hostile, or offensive.

Sexual Harassment. While all types of harassment are prohibited, sexual harassment requires particular attention. Sexual harassment includes sexual advances, requests for sexual favors, and/or other verbal or physical conduct of a sexual nature when:

1. Acceptance of or submission to such conduct is made either explicitly or implicitly a term or condition of employment or education.
2. The individual's response to such conduct is used as a basis for employment decisions affecting an employee or as a basis for educational, disciplinary, or other decisions affecting a student.
3. Such conduct interferes with an individual's job duties, education, or participation in extracurricular activities.
4. The conduct creates an intimidating, hostile, or offensive work or school environment.

II. HARASSMENT AND RETALIATION PROHIBITED

Harassment in any form or for any reason is absolutely forbidden. This includes harassment by administrators, certified and support personnel, students, vendors, and other individuals in school or at school related events. In addition, retaliation against any individual who has brought harassment or other inappropriate behavior to the attention of the school or who has cooperated in an investigation of a complaint under this policy is unlawful and will not be tolerated by Orangeburg Preparatory Schools.

Persons who engage in harassment or retaliation may be subject to disciplinary action including, but not limited to, reprimand, suspension, termination/expulsion or other sanctions as determined by the school administration and/or school committee, subject to applicable procedural requirements.

III. INVESTIGATION

Any individual who believes he or she has been harassed, or who has witnessed or learned about the harassment of another person in the school environment, has the right to file a complaint with Orangeburg Preparatory Schools. This may be done in writing or orally by informing the Head of School as soon as possible.

Orangeburg Preparatory Schools will promptly investigate every complaint of harassment. If it determines that harassment has occurred, it will take appropriate action to end the harassment and to ensure that it is not repeated. Confidentiality will be maintained to the extent consistent with the school's obligations under law and under applicable collective bargaining agreements and to the extent practicable.

In certain cases, the harassment of a student may constitute child abuse under state law. Orangeburg Preparatory Schools will comply with all legal requirements governing the reporting of suspected cases of child abuse and will report suspected criminal activity to the appropriate authorities.

IV. CLOSURE OF A COMPLAINT

When an investigation has been completed, school personnel will inform the complainant of the results. Orangeburg Preparatory Schools urges all individuals in the school community to bring any concerns or complaints of harassment to the attention of school personnel as soon as possible so that they can resolve the issue.

2023-2024**Orangeburg Preparatory Schools**

Plagiarism, legally known as intellectual theft, is defined by *Encyclopedia Americana* (2003) as “the reproduction, in whole, or essential part, or a literary, artistic, or musical work by one who falsely claims to be its creator.” Plagiarism includes, but is not limited to:

- Downloading a paper or portions of a paper from an internet “paper-mill.”
- Submitting work created by another student.
- Copying a portion of someone else’s work without properly citing it.
- Copying material, supplying proper documentation, but omitting quotes or indentions.
- Paraphrasing ideas without proper documentation.

Plagiarism is regarded as a very serious offense, and in extreme cases, may have legal consequences outside the school environment. Many institutions of higher learning have expulsion policies to deal with students who commit plagiarism. Federal copyright laws protect many published works, and criminal penalties may be pursued. In an effort to make our students aware of the consequences of plagiarism, we have established the following guidelines and penalties:

VIOLATION	PROCEDURE	PENALTY
Copying homework/classwork	The teacher notes the plagiarism, issues a Level 2 Detention, and notifies the Administration.	Level 2 Detention; “0” grade for the assignment
Plagiarism in any non-major writing assignment, paper, or project	The teacher notes the plagiarism and refers the situation to the Administration	Level 3 Detention; “0” grade for the assignment
Plagiarism in any major writing assignment, such as term papers and other major projects	The teacher notes the plagiarism and refers the student to the Administration	Level 3 Detention; “0” grade for the assignment

- Students should be aware that they may be requested to submit assignments to a plagiarism detection website or the teacher may conduct an internet search relevant to the content of the paper should plagiarism be suspected.
- Utilizing and/or submitting AI-generated content without proper citation.

Social Media

Student, Parent/Guardian

Orangeburg Preparatory Schools believes that a positive and constructive relationship between the school, the student, and the parent(s)/guardian and/or other family members is essential to the mission of the school. Thus, the school reserves the right to discipline or dismiss the student if the administration concludes that the actions on social media by the student, parent, guardian, or family impede the school's ability to meet its educational objectives or to make a positive or constructive relationship impossible.

July 2023						
Su	Mo	Tu	We	Th	Fr	Sa
						1
2	3	4	5	6	7	8
9	10	11	12	13	14	15
16	17	18	19	20	21	22
23	24	25	26	27	28	29
30	31					

August 2023						
Su	Mo	Tu	We	Th	Fr	Sa
		1	2	3	4	5
6	7	8	9	10	11	12
13	14	15	16	17	18	19
20	21	22	23	24	25	26
27	28	29	30	31		

September 2023						
Su	Mo	Tu	We	Th	Fr	Sa
					1	2
3	4	5	6	7	8	9
10	11	12	13	14	15	16
17	18	19	20	21	22	23
24	25	26	27	28	29	30

October 2023						
Su	Mo	Tu	We	Th	Fr	Sa
1	2	3	4	5	6	7
8	9	10	11	12	13	14
15	16	17	18	19	20	21
22	23	24	25	26	27	28
29	30	31				

November 2023						
Su	Mo	Tu	We	Th	Fr	Sa
			1	2	3	4
5	6	7	8	9	10	11
12	13	14	15	16	17	18
19	20	21	22	23	24	25
26	27	28	29	30		

December 2023						
Su	Mo	Tu	We	Th	Fr	Sa
					1	2
3	4	5	6	7	8	9
10	11	12	13	14	15	16
17	18	19	20	21	22	23
24	25	26	27	28	29	30
31						

July 24 Class of 2024 Photographs
 August 10,11 New Teacher Orientation
 August 14,15,16 Teacher Workdays
 August 15 Open House
 August 17 School Opens, 4K-12 11:30 Dismissal
 August 23 Grades 6-11 & Senior Make-up Pictures
 August 29 First Grade—Fifth Grade Pictures
 August 30 CDC through 5K Pictures
 September 4 Labor Day Holiday
 October 2 Lower & Upper School Make-up Pictures
 October 2-6* Spirit Week
 October 6 Homecoming
 October 9 Fall Break Holiday
 October 17 First Quarter Ends
 October 20 First quarter report cards issued/posted
 October 24 Halloween Carnival
 November 3 OPS Hosting) Holiday / SCISA Teachers' Conference
 November 22,23,24 Thanksgiving Holidays
 December 7 Middle School Christmas Program
 December 8,11(11:30 dismissal on December 12) Review Days for Exams
 December 12-15 *Exams 11:30 Dismissal for Grades 6-12
 December 15 8:30 A.M. Lower Campus Music Program
 11:30 A.M. Dismissal for All Grades
 December 18-January 2 Christmas Holidays (Inclusive)
 January 3 Students Return to School
 January 3 Second Quarter / First Semester Ends
 January 8 Second Quarter / First Semester Reports Issued/Posted
 January 15 Martin Luther King Holiday
 February 16 Professional Development / Holiday for Students
 February 19 Winter Holiday
 March 4-8 Senior Class Trip
 March 13 Third Quarter Ends
 March 14,15 OPS Science Fair
 March 15 Third Quarter Reports Issued / Posted
 March 29-April 5 Spring Break
 April 11 SCISA State Science Fair
 April 12 Prom
 April 16 Lower Campus Group Pictures
 May 1 Awards Day / Upper Campus
 May 2 Senior Exam Review Day
 May 3,6,7 Senior Exams
 May 5 May Day
 May 6* 12 Noon / AP Art History
 May 7* 8:00 a.m. AP Human Geography Exam
 May 10* 8:00 a.m. AP U.S. History Exam
 May 12 7:00 P.M. Baccalaureate
 May 13* 8:00 a.m. AP Calculus
 May 16* 12 noon AP Biology Exam
 May 17 Lower Campus Music Program
 May 17 7:00 P.M. Graduation
 May 17,20 (11:30 dismissal on May 20) Review Days
 May 21-24 Exams @ Upper/ 11:30 Dismissal for Grades 4K-11
 May 21 8:30 A.M. 4K Program
 May 22 8:30 A.M. 5K Graduation
 May 23 8:30 A.M. Awards for Lower Campus, Grades 1-4
 May 24 8:30 A.M. 5th Grade Graduation
 May 24 Last Day of School for Students
 May 27 Memorial Day Holiday
 May 28,29 Teacher Workdays
 May 30 Report Cards Available Online
 May 31, June 3,4 Office Closed

January 2024						
Su	Mo	Tu	We	Th	Fr	Sa
	1	2	3	4	5	6
7	8	9	10	11	12	13
14	15	16	17	18	19	20
21	22	23	24	25	26	27
28	29	30	31			

February 2024						
Su	Mo	Tu	We	Th	Fr	Sa
				1	2	3
4	5	6	7	8	9	10
11	12	13	14	15	16	17
18	19	20	21	22	23	24
25	26	27	28	29		

March 2024						
Su	Mo	Tu	We	Th	Fr	Sa
					1	2
3	4	5	6	7	8	9
10	11	12	13	14	15	16
17	18	19	20	21	22	23
24	25	26	27	28	29	30
31						

April 2024						
Su	Mo	Tu	We	Th	Fr	Sa
	1	2	3	4	5	6
7	8	9	10	11	12	13
14	15	16	17	18	19	20
21	22	23	24	25	26	27
28	29	30				

May 2024						
Su	Mo	Tu	We	Th	Fr	Sa
			1	2	3	4
5	6	7	8	9	10	11
12	13	14	15	16	17	18
19	20	21	22	23	24	25
26	27	28	29	30	31	

June 2024						
Su	Mo	Tu	We	Th	Fr	Sa
						1
2	3	4	5	6	7	8
9	10	11	12	13	14	15
16	17	18	19	20	21	22
23	24	25	26	27	28	29
30						

*Revised 6.22.23

*During first semester exam days, Lower Campus will attend full days with the exception of early dismissal on the last exam day.

Exam Days	Holidays / No School	Faculty Work-days	School Days	Approved 2.21.23
-----------	----------------------	-------------------	-------------	------------------